

# AWT420

## Universal 4-wire, dual-input transmitter



Measurement made easy

—  
AWT420  
Universal 4-wire,  
dual-input transmitter

### Introduction

The AWT420 is a universal 4-wire, dual-input transmitter suitable for the measurement and control of a wide range of parameters including pH, ORP, conductivity, turbidity/suspended solids and dissolved oxygen.

The AWT420 supports both traditional analog and advanced digital EZLink sensors.

This Commissioning Instruction provides installation, operation and maintenance procedures for the AWT420 transmitter. For information on the sensors, including installation, commissioning, operation and maintenance procedures, refer to the specific sensor manual.

### For more information

Further publications for the AWT420 transmitter are available for free download from: [www.abb.com/measurement](http://www.abb.com/measurement) or by scanning this code:



Links and reference numbers for the transmitter publications are also shown below:

**Search for/click on:**

AWT420 transmitter – Data Sheet	<a href="#">DS/AWT420-EN</a>
AWT420 transmitter – Operating Instruction	<a href="#">OI/AWT420-EN</a>
AWT420 transmitter – HART Communications Supplement	<a href="#">COM/AWT420/HART-EN</a>
AWT420 transmitter – HART FDS Communications Supplement	<a href="#">COM/AWT420/HART/FDS-EN</a>
AWT420 transmitter – PROFIBUS Communications Supplement	<a href="#">COM/AWT420/PROFIBUS-EN</a>
AWT420 transmitter – MODBUS Communications Supplement	<a href="#">COM/AWT420/MODBUS-EN</a>
AWT420 transmitter – Ethernet Communications Supplement	<a href="#">COM/AWT420/ETHERNET-EN</a>

## Contents

<b>1</b>	<b>Health &amp; Safety</b> . . . . .	<b>4</b>	<b>7</b>	<b>Operation</b> . . . . .	<b>19</b>
	Document symbols . . . . .	4		Front panel keys . . . . .	19
	Safety precautions . . . . .	4		Modes of operation . . . . .	20
	Potential safety hazards . . . . .	4		Operator menus . . . . .	20
	AWT420 transmitter – electrical . . . . .	4		Operating modes . . . . .	21
	Safety standards . . . . .	4		View mode . . . . .	23
	Product symbols . . . . .	4		Diagnostics View . . . . .	23
	Product recycling and disposal			Signals View . . . . .	23
	(Europe only) . . . . .	5		Chart View . . . . .	23
	End-of-life battery disposal . . . . .	5		Alarms View . . . . .	23
	Information on ROHS Directive			Outputs View . . . . .	23
	2011/65/EU (RoHS II) . . . . .	5		Log mode . . . . .	24
	Cleaning . . . . .	5		Log entries . . . . .	24
<b>2</b>	<b>Cyber security</b> . . . . .	<b>5</b>	<b>8</b>	<b>Data logging</b> . . . . .	<b>25</b>
	Communication protocol specific . . . . .	5		<b>Removable SD card</b> . . . . .	<b>25</b>
<b>3</b>	<b>Overview</b> . . . . .	<b>6</b>		Removable media . . . . .	25
				SD card insertion and removal . . . . .	25
<b>4</b>	<b>Mechanical installation</b> . . . . .	<b>6</b>	<b>9</b>	<b>Password security and Access Level</b> . . . . .	<b>26</b>
	Transmitter installation . . . . .	6		Setting passwords . . . . .	26
	Optional accessories . . . . .	6		Access Level . . . . .	26
	Location . . . . .	6	<b>10</b>	<b>Sensor setup</b> . . . . .	<b>27</b>
	Sensor installation . . . . .	6		2-electrode conductivity . . . . .	27
	Transmitter dimensions . . . . .	7		2-electrode conductivity –	
	Optional weathershield dimensions . . . . .	7		dual input calculated values setup . . . . .	28
	Sensor modules . . . . .	7		4-electrode conductivity . . . . .	29
	Communication module . . . . .	7		pH/Redox/ORP . . . . .	30
	Wall-mounting . . . . .	7		RDO . . . . .	31
	Panel-mounting (optional) . . . . .	8		Turbidity/Suspended solids . . . . .	31
	Pipe-mounting (optional) . . . . .	9	<b>11</b>	<b>Specification</b> . . . . .	<b>32</b>
<b>5</b>	<b>Electrical installation</b> . . . . .	<b>10</b>		Operation . . . . .	32
	Earth bonding . . . . .	10		Mechanical data . . . . .	32
	Cable entries . . . . .	10		Security . . . . .	32
	Terminal connections . . . . .	11		Electrical . . . . .	32
	Digital I/O, relays and analog output connections . . . . .	12		Analog outputs . . . . .	32
	Conductivity sensor module connections . . . . .	12		Relay outputs . . . . .	32
	2-electrode sensors . . . . .	12		Digital input/output . . . . .	32
	4-electrode sensors . . . . .	12		Connectivity/Communications (optional) . . . . .	33
	pH and conductivity connections . . . . .	13		Data logging . . . . .	33
	pH/ORP/plon sensor module connections . . . . .	13		Environmental data . . . . .	33
	Power supply connection . . . . .	14		2-electrode conductivity . . . . .	33
	Fitting the EZLink modules . . . . .	16		4-electrode conductivity . . . . .	34
	Connecting EZLink sensors . . . . .	18		pH/ORP (Redox) . . . . .	34
	Long cables . . . . .	18		EZLink . . . . .	35
<b>6</b>	<b>Easy Setup</b> . . . . .	<b>18</b>		EMC . . . . .	35
				Approvals, certification and safety . . . . .	35

<b>12 Spares</b> .....	<b>37</b>
Sensor module assemblies .....	37
AWT420 pH PCB upgrade/spares kit .....	37
AWT420 2-electrode conductivity PCB upgrade/spares kit .....	37
AWT420 4-electrode conductivity PCB upgrade/spares kit .....	37
EZLink module assemblies .....	37
AWT420 EZLink PCB upgrade/spares kit .....	37
Communications module assemblies .....	37
AWT420 HART PCB upgrade/spares kit .....	37
AWT420 Profibus PCB upgrade/spares kit .....	37
AWT420 Modbus PCB upgrade/spares kit .....	37
AWT420 Ethernet PCB upgrade/spares kit .....	37
AWT420 analog output PCB upgrade/ spares kit .....	37
Mounting kits .....	38
Panel-mount kit .....	38
Pipe-mount kit .....	38
Wall-mount kit .....	38
Weathershield kits .....	38
Weathershield kit .....	38
Weathershield and pipe-mount kit .....	38
Gland packs/EZLink connectors .....	38
Gland packs .....	38
EZLink connector assembly .....	38

# 1 Health & Safety

## Document symbols

Symbols that appear in this document are explained below:

### DANGER

The signal word '**DANGER**' indicates an imminent danger. Failure to observe this information will result in death or severe injury.

### WARNING

The signal word '**WARNING**' indicates an imminent danger. Failure to observe this information may result in death or severe injury.

### CAUTION

The signal word '**CAUTION**' indicates an imminent danger. Failure to observe this information may result in minor or moderate injury.

### NOTICE

The signal word '**NOTICE**' indicates potential material damage.

#### Note

'**Note**' indicates useful or important information about the product.

## Safety precautions

Be sure to read, understand and follow the instructions contained within this manual before and during use of the equipment. Failure to do so could result in bodily harm or damage to the equipment.

### WARNING

#### Bodily injury

Installation, operation, maintenance and servicing must be performed:

- by suitably trained personnel only
- in accordance with the information provided in this manual
- in accordance with relevant local regulations

## Potential safety hazards

AWT420 transmitter – electrical

### WARNING

#### Bodily injury

To ensure safe use when operating this equipment, the following points must be observed:

- Up to 240 V AC may be present. Be sure to isolate the supply before removing the terminal cover.

Safety advice concerning the use of the equipment described in this manual or any relevant Material Safety Data Sheets (where applicable) can be obtained from the Company, together with servicing and spares information.

## Safety standards

This product has been designed to satisfy the requirements of IEC61010-1:2010 3rd edition 'Safety Requirements for Electrical Equipment for Measurement, Control and Laboratory Use' and complies with US NEC 500, NIST and OSHA.

## Product symbols

Symbols that may appear on this product are shown below:



Protective earth (ground) terminal.



Functional earth (ground) terminal.



Alternating current supply only.



Direct current supply only.



This symbol, when noted on a product, indicates a potential hazard which could cause serious personal injury and/or death. The user should reference this instruction manual for operation and/or safety information.



This symbol, when noted on a product enclosure or barrier, indicates that a risk of electrical shock and/or electrocution exists and indicates that only individuals qualified to work with hazardous voltages should open the enclosure or remove the barrier.



The equipment is protected through double insulation.



Recycle separately from general waste under the WEEE directive.

## Product recycling and disposal (Europe only)



ABB is committed to ensuring that the risk of any environmental damage or pollution caused by any of its products is minimized as far as possible. The European Waste Electrical and Electronic Equipment (WEEE) Directive that initially came into force on August 13 2005 aims to reduce the waste arising from electrical and electronic equipment; and improve the environmental performance of all those involved in the life cycle of electrical and electronic equipment. In conformity with European local and national regulations, electrical equipment marked with the above symbol may not be disposed of in European public disposal systems after 12 August 2005.

### NOTICE

For return for recycling, please contact the equipment manufacturer or supplier for instructions on how to return end-of-life equipment for proper disposal.

### End-of-life battery disposal

The transmitter contains a small lithium battery (located on the processor/display board) that must be removed and disposed of responsibly in accordance with local environmental regulations.

## Information on ROHS Directive 2011/65/EU (RoHS II)



ABB, Industrial Automation, Measurement & Analytics, UK, fully supports the objectives of the ROHS II directive. All in-scope products placed on the market by IAMA UK on and following the 22nd of July 2017 and without any specific exemption, will be compliant to the ROHS II directive, 2011/65/EU.

## Cleaning

The complete transmitter can be hosed down if it has been installed to IP66/NEMA 4X standards, i.e. cable glands are correctly fitted and all unused cable entry holes are blanked off – see page 11 and page 10.

Warm water and a mild detergent can be used.

## 2 Cyber security

This product is designed to be connected to and to communicate information and data via a digital communication interface. It is your sole responsibility to provide and continuously ensure a secure connection between the product and your network or any other network (as the case may be). You shall establish and maintain any appropriate measures (such as but not limited to the application of authentication measures etc.) to protect the product, the network, its system and the interface against any kind of security breaches, unauthorized access, interference, intrusion, leakage and/or theft of data or information.

ABB Ltd and its affiliates are not liable for damages and/or losses related to such security breaches, any unauthorized access, interference, intrusion, leakage and/or theft of data or information.

### Communication protocol specific

The HART protocol is an unsecured protocol, as such the intended application should be assessed to ensure that these protocols are suitable before implementation.

The Modbus protocol is an unsecured protocol, as such the intended application should be assessed to ensure that these protocols are suitable before implementation.

The PROFIBUS PA protocol is an unsecured protocol, as such the intended application should be assessed to ensure that these protocols are suitable before implementation.

The PROFIBUS DP protocol is an unsecured protocol, as such the intended application should be assessed to ensure that these protocols are suitable before implementation.

### 3 Overview

The AWT420 is a universal 4-wire single or dual-input transmitter suitable for the measurement and control of a wide range of parameters including pH, ORP, conductivity, turbidity/ suspended solids and dissolved oxygen (depending on the module[s] fitted).

Sensor and communication modules plug directly into their corresponding slot on the transmitter backboard – see page 11 for module locations.

The AWT420 supports both traditional analog and advanced digital EZLink sensors. The transmitter can be wall-, panel- or pipe-mounted – see page 7.

Information from the sensor is sent to the transmitter via a sensor interface board. The process reading is displayed on the main page and can be displayed as a graph in the **Chart View** – refer to page 23 for details of view options. Diagnostic messages inform the user of the system status and can be logged for review. The system status can also be assessed remotely using optional HART®, MODBUS®, Profibus® or Ethernet communications.

Installation and commissioning is simplified with plug-and-play digital sensor connections and automatic sensor recognition and set-up.

### 4 Mechanical installation

#### Transmitter installation

##### Optional accessories

Optional installation accessories:

- Cable gland kit
- Weathershield
- Panel-mount kit
- Pipe-mount kit

##### Location

For general location requirements refer to Figure 2. Select a location away from strong electrical and magnetic fields. If this is not possible, particularly in applications where mobile communications equipment is expected to be used, screened cables within flexible, earthed metal conduit must be used.

Install in a clean, dry, well ventilated and vibration-free location providing easy access. Avoid rooms containing corrosive gases or vapors, for example, chlorination equipment or chlorine gas cylinders.

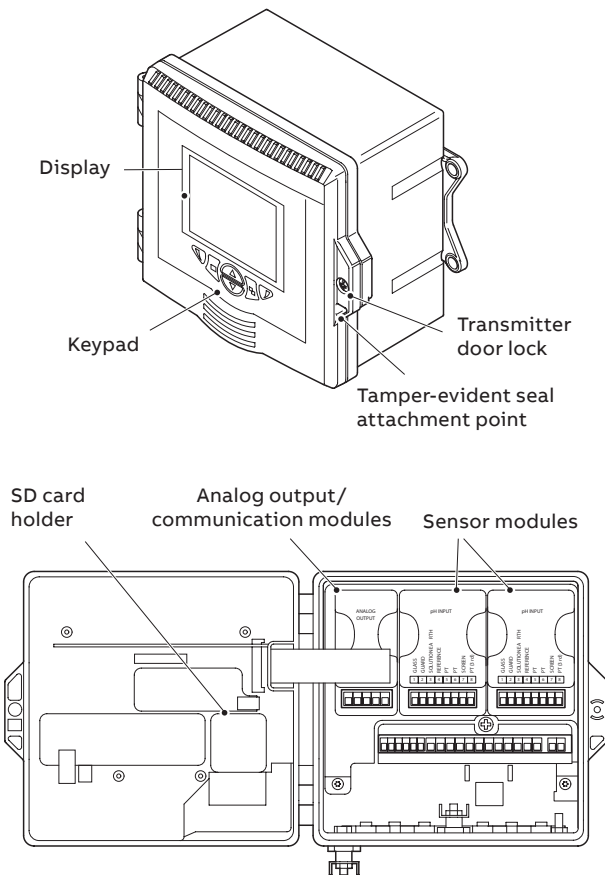

Figure 1 AWT420 transmitter – main components

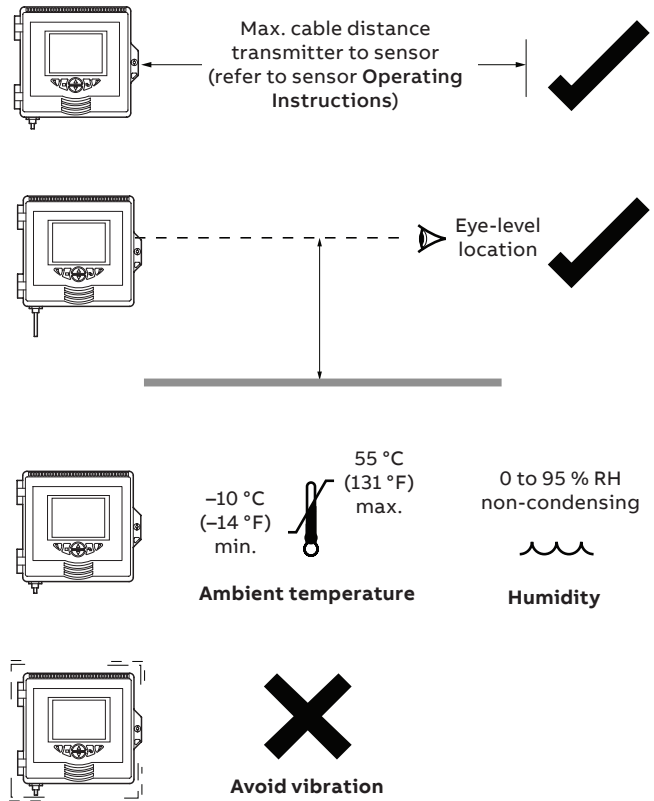

Figure 2 Transmitter location

#### Sensor installation

Refer to the associated sensor Operating Instructions for installation procedures.

**Transmitter dimensions**

Dimensions in mm (in)

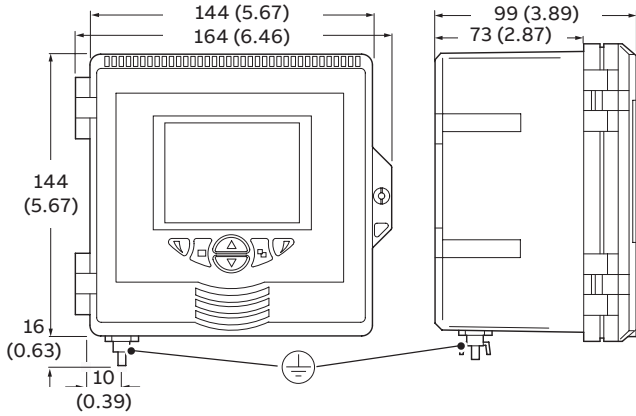

**Figure 3 Transmitter dimensions**

**Optional weathershield dimensions**

Dimensions in mm (in)

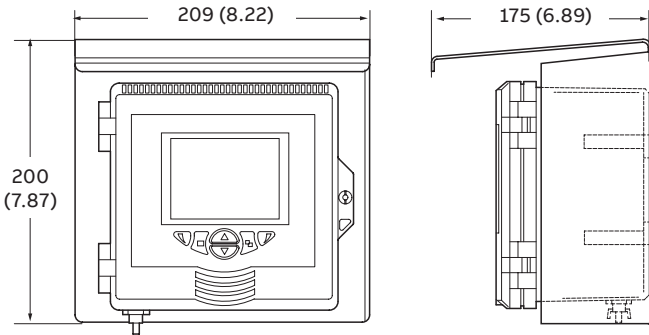

**Figure 4 Optional weathershield dimensions**

**Sensor modules**

Sensor modules are fitted to the transmitter baseboard when the transmitter is configured after being ordered.

**Communication module**

If an optional communication module is ordered, it is fitted to the transmitter baseboard when the transmitter is configured after being ordered.

**Wall-mounting**

Dimensions in mm (in)

**NOTICE**

If the optional weathershield (D) is used, position it between the transmitter and wall and pass 2 screws (C) (not supplied) through fixing holes (both sides) in weathershield.

Referring to Figure 5:

- 1 Position the left- and right-hand mounting brackets (A) into the recesses on the rear of the transmitter as shown and secure with the bracket securing screws. Ensure the plastic washers remain in the positions fitted.
- 2 Mark fixing centers (B) and drill suitable holes in the wall.
- 3 Secure the transmitter to the wall using 2 screws (C) in each mounting bracket.

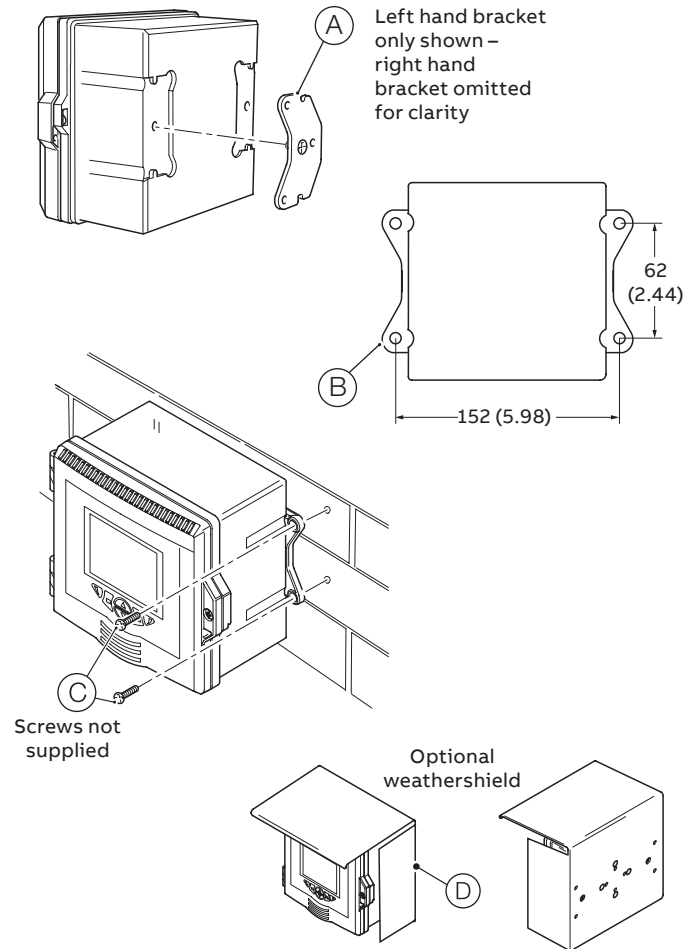

**Figure 5 Wall-mounting the transmitter**

## ...4 Mechanical installation

### ...Transmitter installation

#### Panel-mounting (optional)

Dimensions in mm (in)

Referring to Figure 6:

- 1 Cut the correct sized hole in panel (A).
- 2 Insert the transmitter into the panel cut-out (B).
- 3 Screw one panel clamp anchor screw (C) into the left-hand bracket (D) until 10 to 15 mm (0.39 to 0.59 in) of the thread protrudes from the other side of the bracket and position one clamp (E) over the end of the thread.

#### NOTICE

The correct torque is critical to ensure proper compression of the panel seal and achieve the IP66/NEMA 4X hosedown rating.

- 4 Holding assembly (F) together, position bracket (D) into the left-hand recess on the rear of the transmitter and secure with bracket securing screw (G). Ensure that the plastic washer remains in the position fitted.
- 5 Repeat steps 3 and 4 for the right-hand panel clamp assembly.
- 6 Torque each panel clamp anchor screw to 0.5 to 0.6 Nm (4.42 to 5.31 lbf·in).

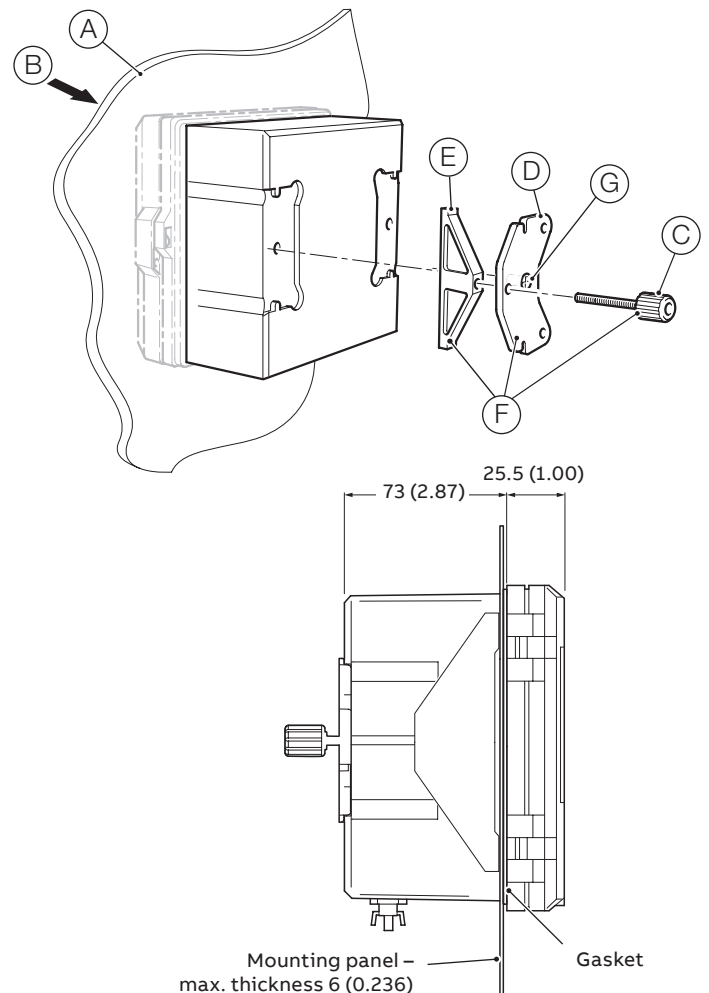
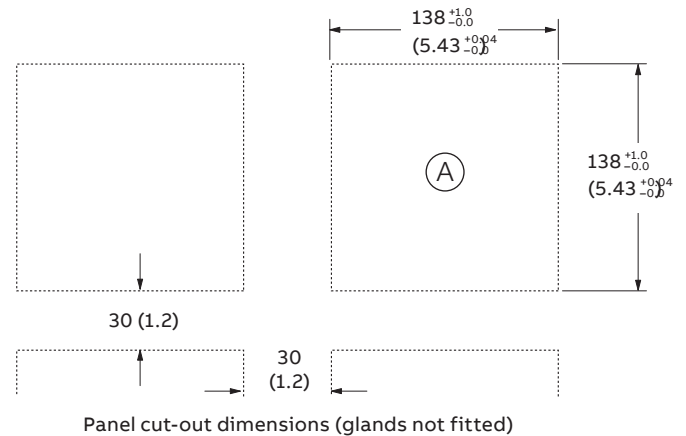

Figure 6 Panel-mounting the transmitter

### Pipe-mounting (optional)

Dimensions in mm (in)

#### NOTICE

If the optional weathershield (F) is used, locate it against the transmitter back panel and attach the pipe-mount kit to the weathershield rear face and transmitter.

Referring to Figure 7, secure the transmitter to a pipe as follows:

- 1 Fit two M6 x 50 mm hexagon-head screws (A) through one clamp plate as shown.
- 2 Using the appropriate holes to suit vertical or horizontal pipe, secure the clamp plate to the pipe-mounting bracket (B) using two M6 x 8 mm hexagon-head screws and spring lock washers (C).
- 3 Position the pipe-mounting bracket into the recesses on the rear of the transmitter as shown and secure with the two bracket securing screws (D). Ensure the plastic washers remain in the positions fitted.
- 4 Secure the transmitter to the pipe using the remaining clamp plate, spring lock washers and nuts (E).

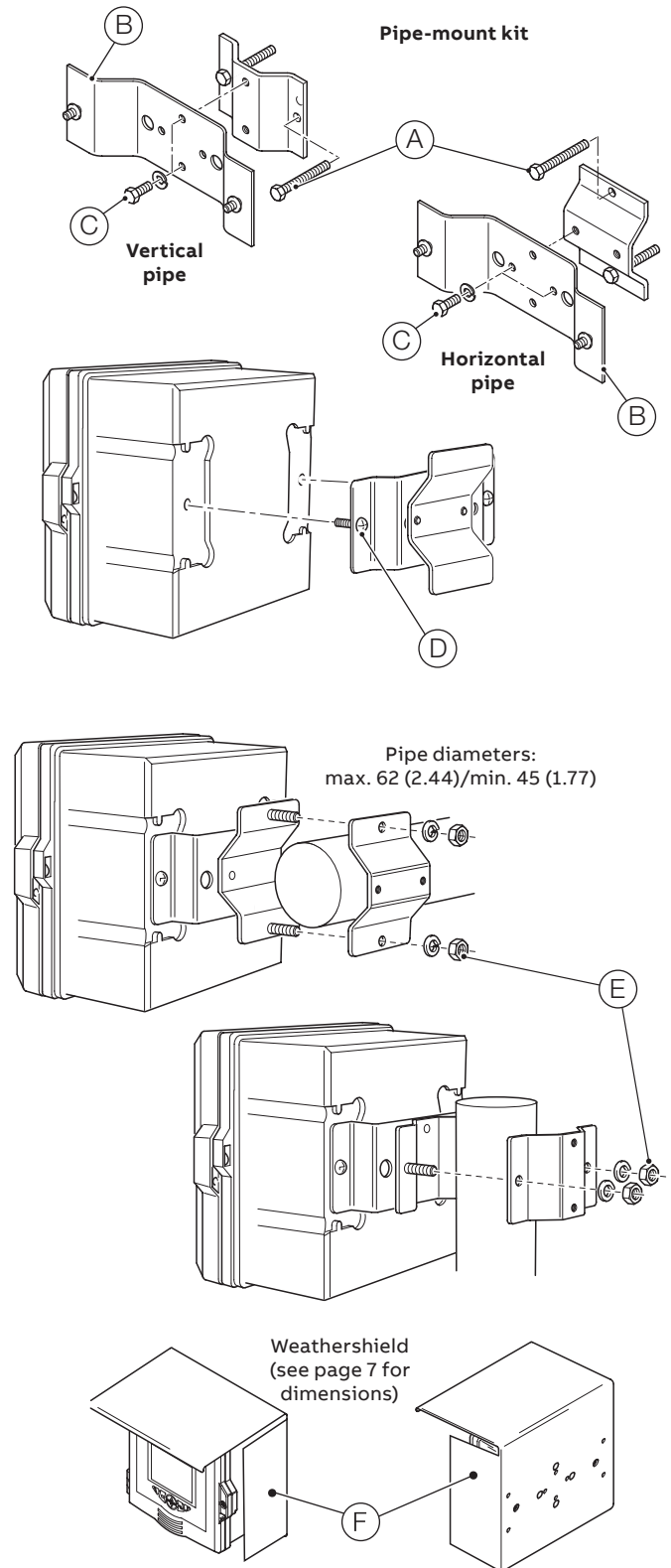

Figure 7 Pipe-mounting the transmitter

## 5 Electrical installation

### **⚠ DANGER**

#### Bodily injury

- **Before making any connections**, the external protective earth stud must be connected to the local earth bonding point using suitably sized ground cable – see page 16.
- The transmitter is not fitted with a switch – an isolation device such as a switch or circuit breaker conforming to local safety standards must be fitted to the final installation. It must be fitted in close proximity to the transmitter, within easy reach of the operator and marked clearly as the isolation device for the transmitter.
- Remove all power from supply, relay, any powered control circuits and high common mode voltages before accessing or making any connections. For the mains power, use 3-core cable rated 3A and for the relay connections use cable rated 5A. Use cable rated 105 °C (221 °F) minimum that conforms to either IEC 60227 or IEC 60245, or to the National Electrical Code (NEC) for the US or the Electrical Code for Canada. The terminals accept cables AWG 24 to 16 (0.2 to 1.5 mm<sup>2</sup>).
- All connections to secondary circuits must have insulation to required local safety standards. After installation, there must be no access to live parts, for example, terminals. Use screened cable for signal inputs and relay connections. Route signal leads and power cables separately, preferably in an earthed (grounded) flexible metal conduit.

#### USA and Canada only

- Supplied cable glands are an optional extra and provided for the connection of MODBUS, Profibus and Ethernet communication wiring **ONLY**. A special cable gland is supplied with the Ethernet communications option and should be used only for the Ethernet cable.
- The use of cable glands, cable/flexible cord for connection of the mains power source to the mains input and relay contact output terminals is not permitted in the USA or Canada.
- For connection to mains (the mains input and relay contact outputs), use only suitably rated field wiring insulated copper conductors rated min. 300 V, 16 AWG, 105 °C (221 °F). Route wires through suitably rated flexible conduits and fittings.

### **⚠ WARNING**

#### Bodily injury

- If the transmitter is used in a manner not specified by the Company, the protection provided by the equipment may be impaired.
- Ensure the correct fuses are fitted – see Figure 9, page 11 for fuse details.
- Replacement of the internal battery must be carried out by an approved technician only.
- The transmitter conforms to Installation Category II of IEC 61010.
- All equipment connected to the transmitter's terminals must comply with local safety standards (IEC 60950, EN61010-1).
- The DC power supply and the optional Ethernet and bus interface connectors must be connected to Safety Extra Low Voltage (SELV) circuits.

### Earth bonding

### **⚠ WARNING**

#### Before making any electrical connections:

- The external protective earth stud (see Figure 11, page 15) must be connected to the local earth bonding point using suitably sized ground cable. To connect to the protective earth stud, use a closed M4 cable lug.
- **Never** connect the protective earth with an end sleeve or an open cable lug.

### Cable entries

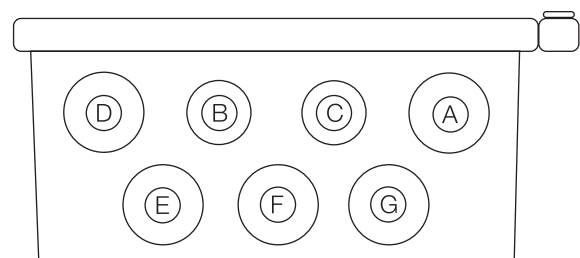

- |                          |                          |
|--------------------------|--------------------------|
| (A) M20 – mains power    | (E) M20 – digital I/O    |
| (B) M16 – sensor 1       | (F) M20 – analog outputs |
| (C) M16 – sensor 2       | (G) M20 – relay contacts |
| (D) M20 – communications |                          |

Figure 8 Cable entries

## Terminal connections

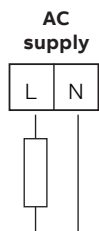
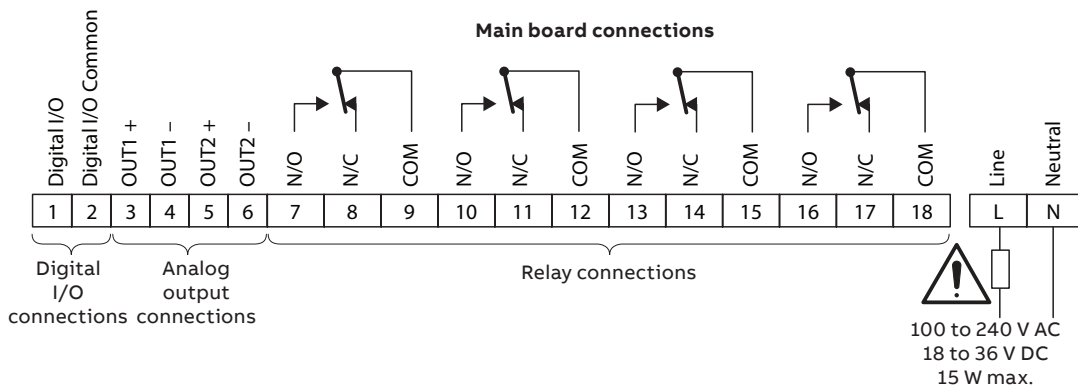
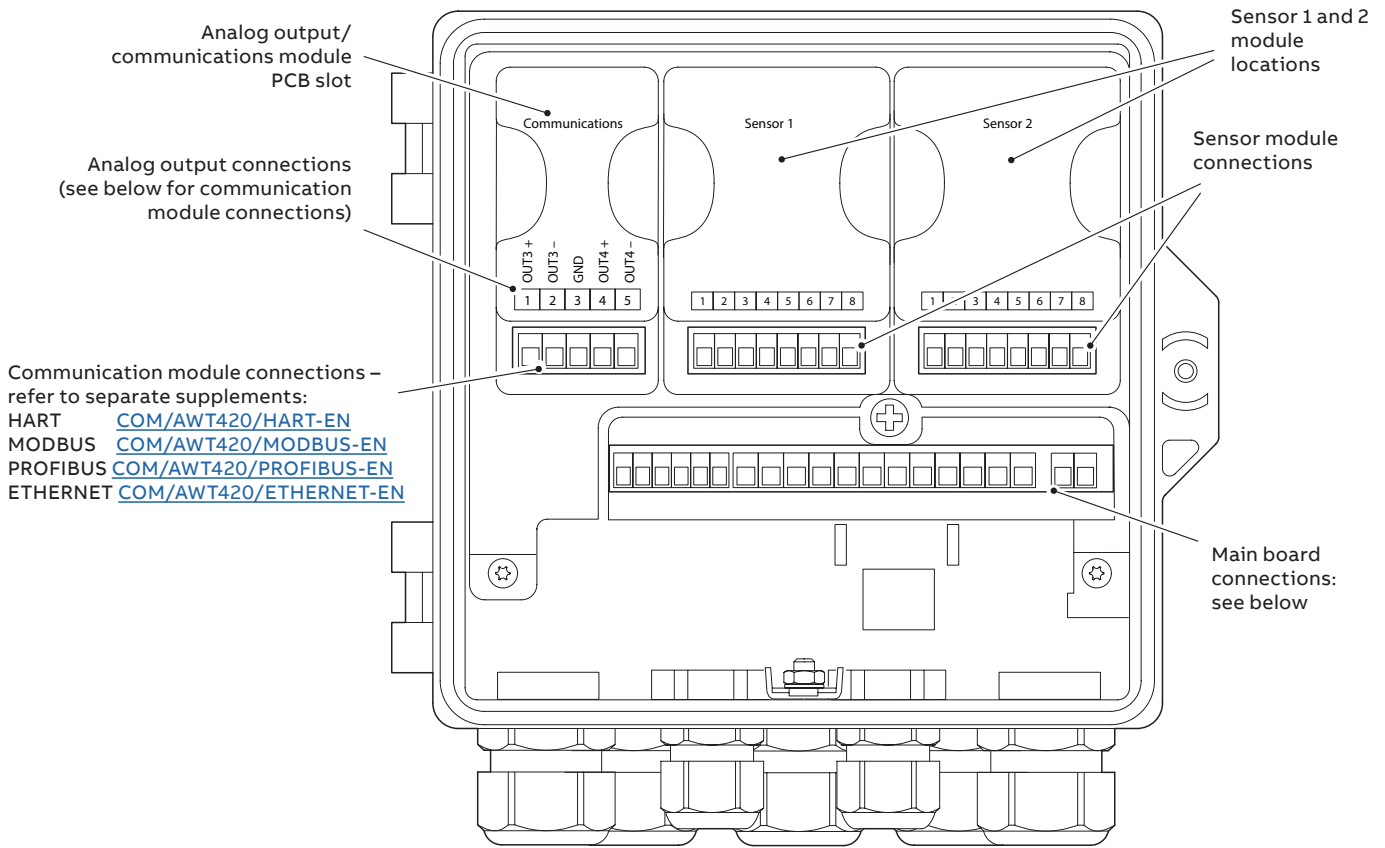

**WARNING**

**Bodily injury**  
 Use fuse rating 500 mA (maximum) type TIR (UL category JDYX2)

100 to 240 V AC  $\pm 10\%$ , 50/60 Hz  
 (90 min. to 264 V max. AC, 45/65 Hz)

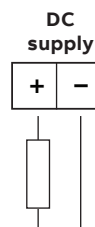

**WARNING**

**Bodily injury**  
 Use fuse rating 2.5 A (maximum) type T (UL category JDYX or JDYX7)

24 V DC nominal  
 (18 min. to 36 V max.)

Figure 9 Electrical connections overview

## ...5 Electrical installation

### Digital I/O, relays and analog output connections

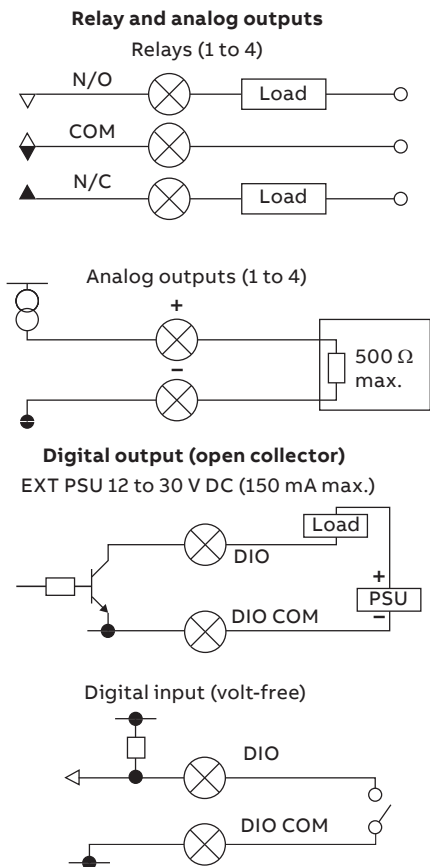

Figure 10 Digital I/O, relays and analog output connections

## Conductivity sensor module connections

### 2-electrode sensors

Sensor type	RTD wiring	DRIVE + 1	2	3	DRIVE - 4	RTD 1 5	RTD 2 6	SHIELD 7	RTD 3 8
2025, 2045	2-lead	Red	-	-	Black	Green/Yellow Blue	Brown	-	-
2077, 2078	3-lead	Red	-	-	Black	Brown	Green/Yellow	-	Blue
2085, 2089	3-lead	Red	-	-	Black	Blue	Yellow	Dark green	-
2085*	2-lead	Red	-	-	Blue	Yellow	Dark green	-	-
TB2	2-lead	Green	-	-	Black	Blue	Yellow	Dark green	-
AC2xx	2-lead	Green	-	-	Black	Blue/Red	Yellow	Dark green	-
	3-lead	Green	-	-	Black	Yellow	Red	Dark green	Blue

\*2085 cable attached cells

### 4-electrode sensors

Sensor type	RTD wiring	DRIVE + 1	SENSE + 2	SENSE - 3	DRIVE - 4	RTD 1 5	RTD 2 6	SHIELD 7	RTD 3 8
TB4	2-lead	Green	Red	White	Black	Blue	Yellow	Dark green	-

## pH and conductivity connections

### pH/ORP/plon sensor module connections

#### NOTICE

ORP (Redox) and Antimony pH sensors do not feature temperature compensation therefore do not have temperature sensors or related wiring.

### Standard sensors without diagnostic functions

#### NOTICE

Ensure sensor diagnostics are **Off** when using standard sensors without diagnostic functions.

Sensor type	RTD wiring	SENSE 1	GUARD 2	REF 3	S.GND 4	RTD 1 5	RTD 2 6	SHIELD 7	RTD 3 8
2867	2-lead	Clear	–	–	Black	Red	White	–	–
TB5	2-lead	Blue	–	–	Black	Red	White	–	–
AP1xx	2-lead	Clear	–	–	Black	Red Red	White	–	–
	3-lead	Clear	–	–	Black	White	Red	–	Red
AP3xx	2-lead*	Blue	–	–	Black	Red	White	–	–
	3-lead	Blue	–	–	Black	Red	White	–	Grey
APS1xx	2-lead*	Blue	–	–	Black	Red	White	Yellow	–
APS5xx									
APS7xx	3-lead	Blue	–	–	Black	Red	White	Yellow	Grey

\* Cut and remove grey wire

### Standard sensors with diagnostic functions

#### NOTICE

Ensure sensor diagnostics are **On** when using standard sensors with diagnostic functions.

Sensor type	RTD wiring	SENSE 1	GUARD 2	REF 3	S.GND 4	RTD 1 5	RTD 2 6	SHIELD 7	RTD 3 8
TBX5	2-lead	Blue	Yellow	Black	Green	Red	White	Dark green	–
AP2xx	2-lead*	Clear	Red	Blue	Green/Yellow	Red	White	–	–
	3-lead	Clear	Red	Blue	Green/Yellow	Red	White	–	Grey

\* Cut and remove grey wire

## ...5 Electrical installation

### Power supply connection

#### WARNING

##### Bodily injury – USA and Canada only

- The use of cable glands, cable/flexible cord for connection of the mains power source to the mains input and relay contact output terminals is not permitted.

#### NOTICE

##### Electrical installation – ABB recommendations:

- Ferrules are fitted to all cables.
- Use M4 ring terminals (crimped) on the earth conductor prior to fitting to the earth stud on the gland plate (plastic enclosure) or M5 ring terminals prior to fitting to the earth boss (metal enclosure).
- Only 1 cable per cable gland.

Referring to Figure 11, page 15:

- 1 Using a suitable screwdriver, release door retaining screw (A) and open the transmitter door.
- 2 Release terminal cover retaining screw (B) and remove terminal cover plate (C).
- 3 Slide retaining clip (D) off blanking plug (E) and remove the blanking plug if fitted.
- 4 Fit cable gland (F) and secure using nut (G).
- 5 Remove gland cover (H) and route mains power supply cable (I) through it.
- 6 Route the cable through cable gland (F) and into the enclosure case.

#### NOTICE

Use a single-holed bush for the mains power cable.

- 7 Make connections to the power supply connection terminals (J). Connect earth wire (K) to earth stud (L).
- 8 Tighten gland cover (H).
- 9 Refit terminal cover (C) and secure it with retaining screw (B).
- 10 Close the transmitter door and secure with door retaining screw (A).

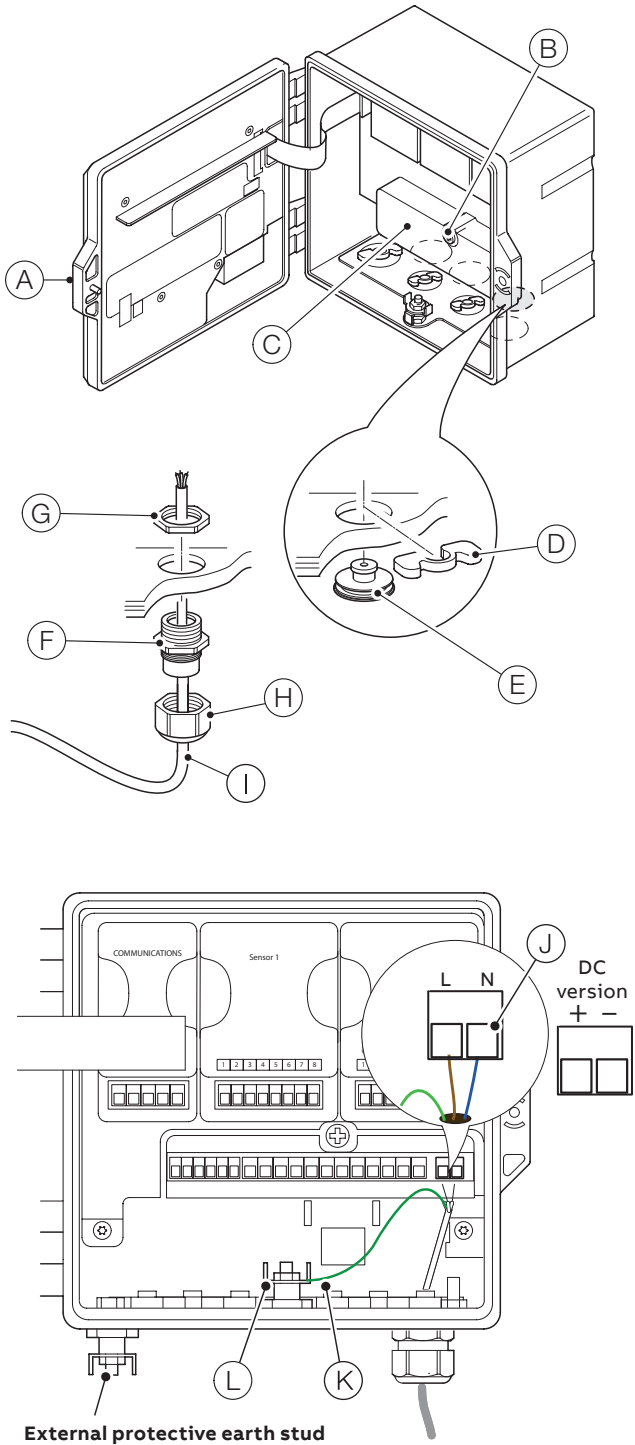

Figure 11 Connecting the transmitter AC mains power supply

## ...5 Electrical installation

### Fitting the EZLink modules

#### WARNING

##### Bodily injury

- Up to 240 V AC may be present. Isolate the power supply before removing the opening the transmitter door.

Referring to Figure 12:

- 1 Remove connector block cradle (A) from EZLink module(s) and retain for connection.
- 2 Unlock and open transmitter door (B).
- 3 Fit EZLink modules as follows:
  - a if one EZLink module is used, push-fit it into location (C) (sensor 1).  
**Note.** When fitting the cable assembly, the EZLink connector for sensor 1 passes through cable entry (D).
  - b if two EZLink modules are used, push-fit sensor 1 module into location (C) and sensor 2 module into location (E).  
**Note.** When fitting the cable assemblies, the EZLink connector for sensor 1 passes through cable entry (D) and the EZLink connector for sensor 2 passes through cable entry (F).

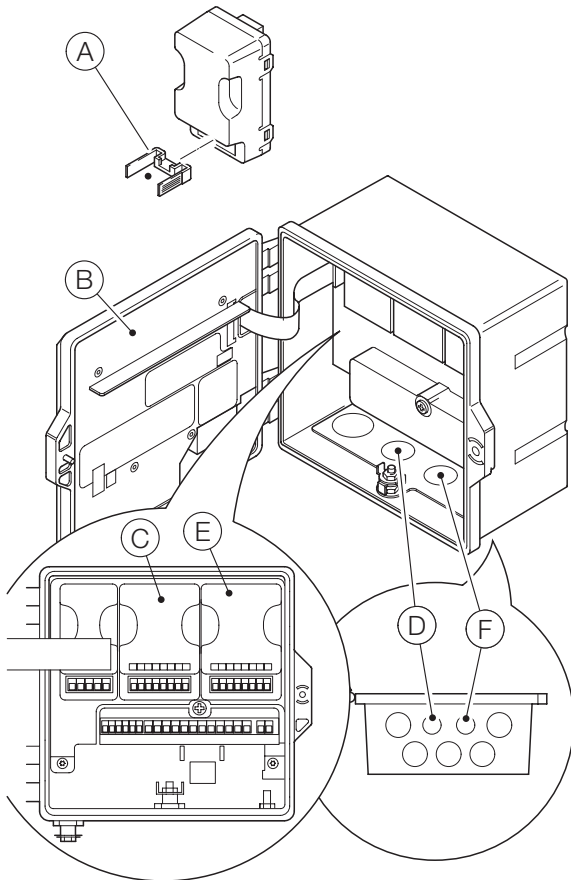

Figure 12 EZLink module positions and EZLink cable entries

Referring to Figure 13:

- 4 Pass EZLink connector cable (G) through the correct cable entry – see step 3.
- 5 Pass thread alignment washer (H) over EZLink connector cable (G), ensuring alignment tab (I) is orientated correctly.
- 6 Pass thread back nut (J) over EZLink connector cable (G).

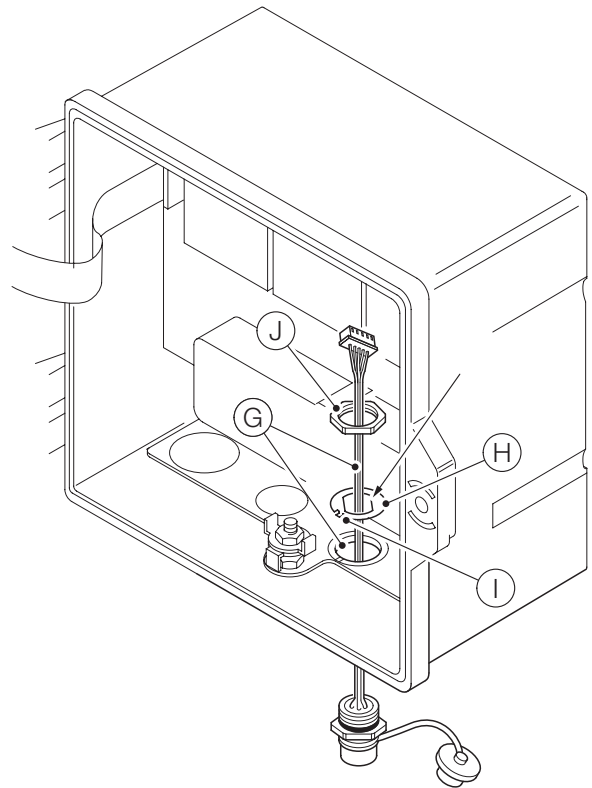
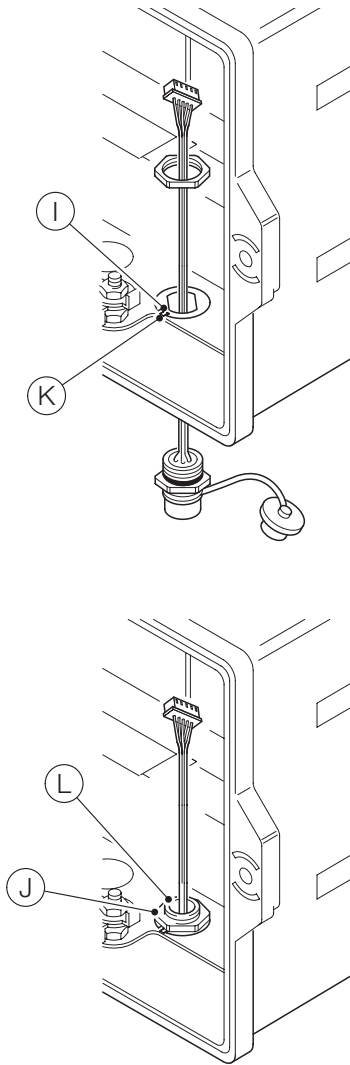

Figure 13 Preparing EZLink connector cable fixings

Referring to Figure 14:

- 7 Fit alignment tab (I) into gland plate slot (K) (on plastic case variant) or in the casting slot (on metal case variant).
- 8 Insert EZLink connector body (L) fully into cable entry and align the connector body using the flats on the alignment washer (see Figure 13).
- 9 Screw back nut (J) onto connector body and tighten using a spanner.



**Figure 14** Securing the EZLink connector cable assembly

Referring to Figure 15:

- 10 Place EZLink cable plug (M) into EZLink connector block cradle (A).
- 11 Plug connector block cradle (A) into EZLink module (N).

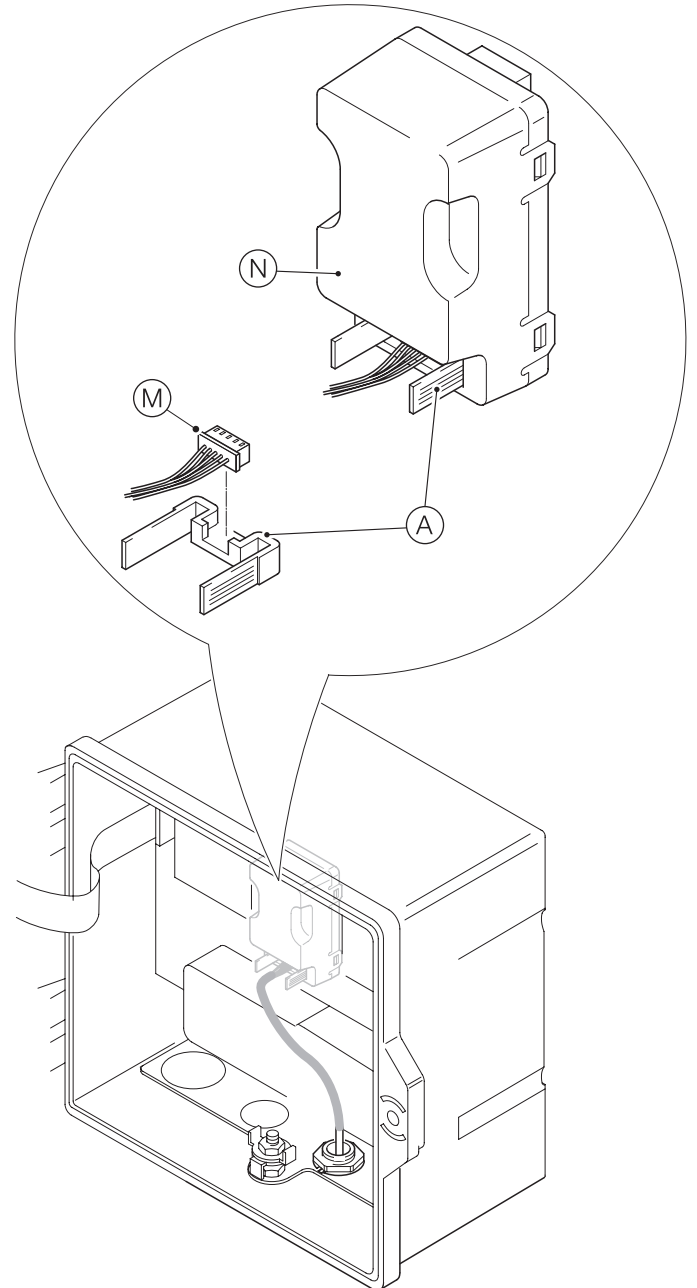

**Figure 15** Connecting the EZLink cable assembly

- 12 If a second EZLink module is required, repeat all steps.
- 13 Close and lock transmitter door (B).

## ...5 Electrical installation

### Connecting EZLink sensors

#### NOTICE

Maximum length of cable from transmitter to sensor(s) – refer to sensor Operating instruction.

Referring to Figure 16:

- 1 Align the pins in sensor cable connector (A) with the holes in EZLink connector (B) and push the connectors together.
- 2 Turn nut (C) clockwise to secure the connectors together.

The transmitter detects the type of sensor connected automatically.

#### NOTICE

When installing sensor extension cables, ensure the male end (end with label) of the cable is installed towards the transmitter.

#### Long cables

If cables are longer than 30 m (94 ft), or they are outside, the following cables must be screened or contained in conductive conduit:

- digital I/O
- analog outputs
- communication

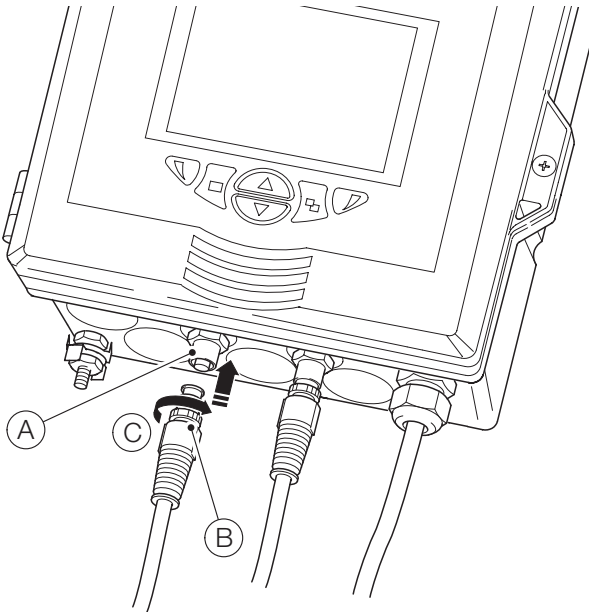
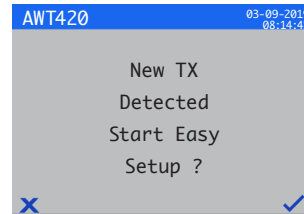

Figure 16 Connecting the sensor EZLink connector(s)

## 6 Easy Setup

When the transmitter is started up for the first time, or when Restore defaults is selected from the Configuration/Device Setup/Initial Setup menu (see page 29), the 'Easy Setup' prompt is displayed:



Press the key () to start Easy Setup or press the key () to cancel and exit to the main Operator page.

Press the key (Edit) to change the default value/setting to the required value/selection. Press the key (Next) to accept the default or revised value/selection and advance to the next parameter.

Transmitter parameters that can be configured in this way are: Language, Instrument Tag, Diagnostics View, Signals View, Chart View, Alarm View, Analog OP View, Calibration Log, Alarm Log, Audit Log, Diagnostics Log, Date Format and Date & Time. On completion of Easy Setup, the display returns to the Easy Setup start screen:

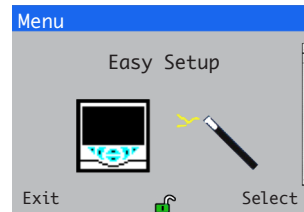

Press the key (Select) to revise/amend the settings just made or press the key (Exit) to cancel and exit to the main Operator page.

All transmitter parameters can be revised/changed at any time by selecting Enter Configuration from any Operator or View page menu, followed by Advanced from the Access Level menu.

#### NOTICE

- If Easy Setup does not detect a key press within 5 minutes, the display changes automatically to the main Operator page.
- Refer to page 19 for details of menu navigation and parameter selection/adjustment.

## 7 Operation

### Front panel keys

The transmitter is operated using the front panel keys. Prompts associated with active keys are displayed on each

screen.

Diagnostic messages are detailed on page 64, display icon descriptions are detailed on page 27.

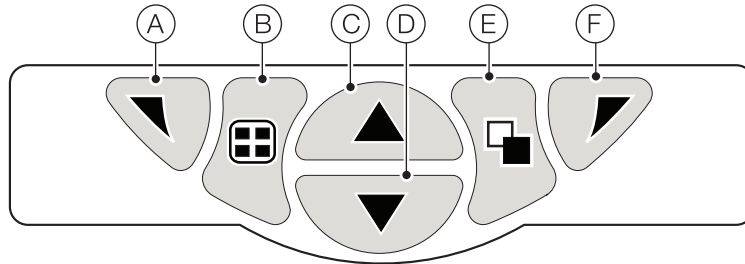

Figure 17 Front panel keys

Key	Function	Description
(A)	Navigation key – left and Operator menu access key	When any <b>Operating</b> , <b>View</b> or <b>Log</b> page is displayed, opens or closes the <b>Operator</b> menu and returns to the previous menu level.
(B)	View key	Toggles the view between <b>Operator</b> pages, <b>View</b> screens and <b>Log</b> screens – see Figure 18. <b>Note.</b> Disabled in <b>Configuration</b> mode.
(C)	Up key	Used to navigate up menu lists, highlight menu items and increase displayed values.
(D)	Down key	Used to navigate down menu lists, highlight menu items and decrease displayed values.
(E)	Group key	Toggles between: <ul style="list-style-type: none"> <li>• <b>Operator</b> pages (1 to 5) when an <b>Operator</b> page is selected with the <b>View</b> key.</li> <li>• <b>View</b> screens (<b>Diagnostics View</b>, <b>Signals View</b>, <b>Alarms View</b>, and <b>Outputs View</b>) when the <b>Diagnostics View</b> screen is selected with the <b>View</b> key.</li> <li>• <b>Log</b> screens (<b>Calibration Log</b>, <b>Alarm Log</b>, <b>Audit Log</b> and <b>Diagnostics Log</b>) when the <b>Calibration Logs</b> screen is selected with the <b>View</b> key.</li> </ul> See Figure 18. <b>Note.</b> Disabled in <b>Configuration</b> mode.
(F)	Navigation key – right and Cal shortcut key	At menu level, selects the highlighted menu item, operation button or edits a selection. When any <b>Operator</b> , <b>View</b> or <b>Log</b> page is displayed, used as a shortcut key to access the <b>Calibrate</b> level.

Table 1 Key functions

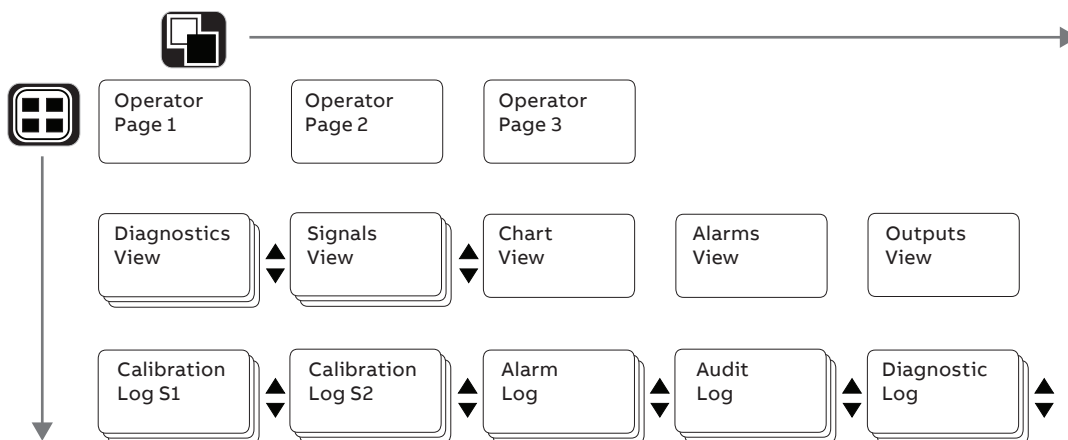

Figure 18 Menu navigation overview

**Note.**

The calibration log for a sensor (S1 to S2) is displayed only if that sensor is fitted.

## ...7 Operation

### Modes of operation

The transmitter has 4 modes of operation – all modes are accessed from the **Operator** menu – see Figure 19:

- **Operating:** displays real-time sensor values on **Operating Pages** – see page 21.
- **View:** displays diagnostic messages, alarms, output values, signals (including the flow rate where applicable) and (chart) traces – see page 23.
- **Log:** displays recorded diagnostic, calibration and audit events and alarms – see page 24.
- **Configuration:** enables the transmitter to be configured – see page 27.

### Operator menus

#### NOTICE

Operator menu cannot be accessed directly from the Configuration level.

Referring to Figure 19:

- **Operator menu** (A) are accessed from any **Operator**, **View** or **Log** page by pressing the **↵** key (B).
- **Operator sub-menu** (indicated by the arrow) are selected by pressing the **↵** key (C).
- The **Calibrate** page can be opened directly from an **Operator** page (bypassing the **Configuration** level menus) using **CAL** shortcut (D). Press the **↵** key (C) (below the **CAL** prompt).

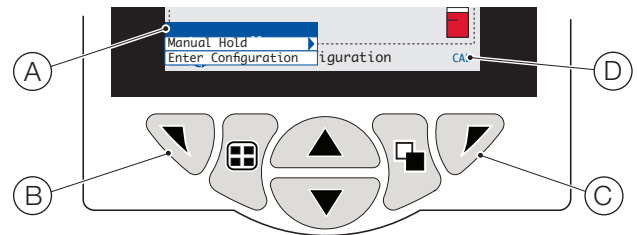

Figure 19 Operator menus

Operator menus comprise:

- **Operator Pages:** displays the **Operator** page for each available sensor.
- **Data Views:** displays enabled data views.
- **Logs:** displays enabled Log views.
- **Alarm Acknowledge:** acknowledges the active alarm displayed in the **Alarms View**.
- **Manual Hold:** holds (freezes) the current outputs and alarms for the selected sensor(s).

#### NOTICE

Active values are still indicated on the display.

- **Manual Clean:** initiates a sensor cleaning cycle.
- **Ack.Sensor Removed** (displayed only if a sensor is disconnected from the transmitter): confirms permanent sensor removal and resets transmitter configuration settings to factory default for the sensor input.
- **Media Card:** displays the status of the SD card and enables the operator to place the media online/offline.
- **Autoscroll** (enabled on **Operator** pages only): displays **Operator** pages sequentially when multiple sensors are fitted.
- **Enter Configuration** (enabled on all pages): enters **Configuration** parameters via the **Access Level** – see page 26 for access levels and password security options.

## Operating modes

In operating mode, process values (PVs) from connected sensors are displayed on **Operator Pages**. A maximum of 3 **Operator Pages** can be displayed.

**Operator Page 1** (the default page) displays the PVs from all connected sensors simultaneously (a maximum of 2 sensors can be connected). The remaining 2 **Operator** pages display values from individual sensors (in sensor order).

In Figure 20, **Operator** page 1 shows that 2 sensors are connected (pH and turbidity).

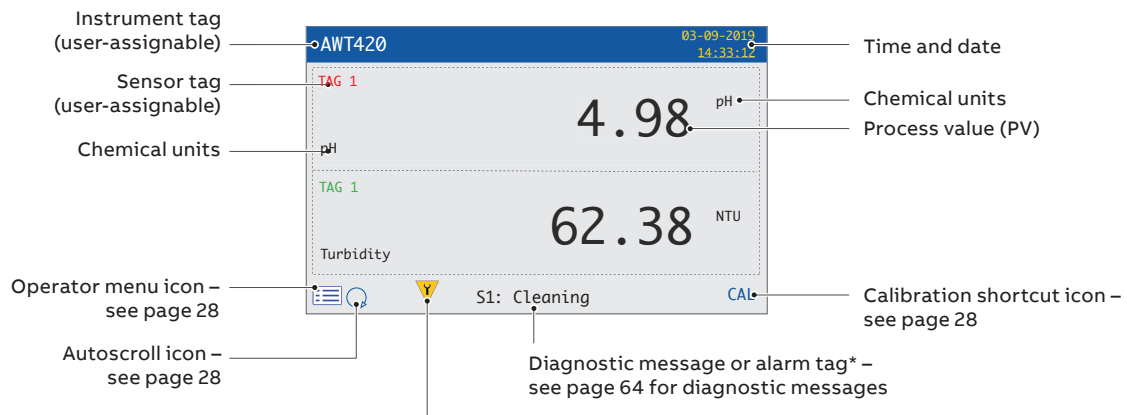

### NAMUR (NE107) Status Icons

	Failure		High Process Alarm
	Maintenance		Low Process Alarm
	Out of Spec		High Latch Alarm
	Check Function		Low Latch Alarm

\*The highest priority diagnostic or alarm is displayed.  
Other active diagnostic/alarm states can be viewed on the **Diagnostics View** – see page 22.

**Figure 20 Operator Page (multiple sensors)**

## ...7 Operation

Figure 21 shows an overview of **Operator** pages 2 to 3. Each **Operator Page** displays the PV and temperature from a single sensor. Fixed, color-coded, user-assignable tags (one for each fitted sensor) and color-coded bargraphs aid identification of each sensor.

The bargraph indicates the PV. Minimum and maximum PVs are configurable in the **Sensor Setup** level. If the measured PV is above the maximum specified range of the sensor (refer to the sensor's **Operating Instruction**), the bargraph flashes to indicate the value is outside the specified range.

When multiple sensors are fitted and **Autoscroll** is selected from the **Operator Menu** (see page 20), the display scrolls through each available **Operator Page** consecutively.

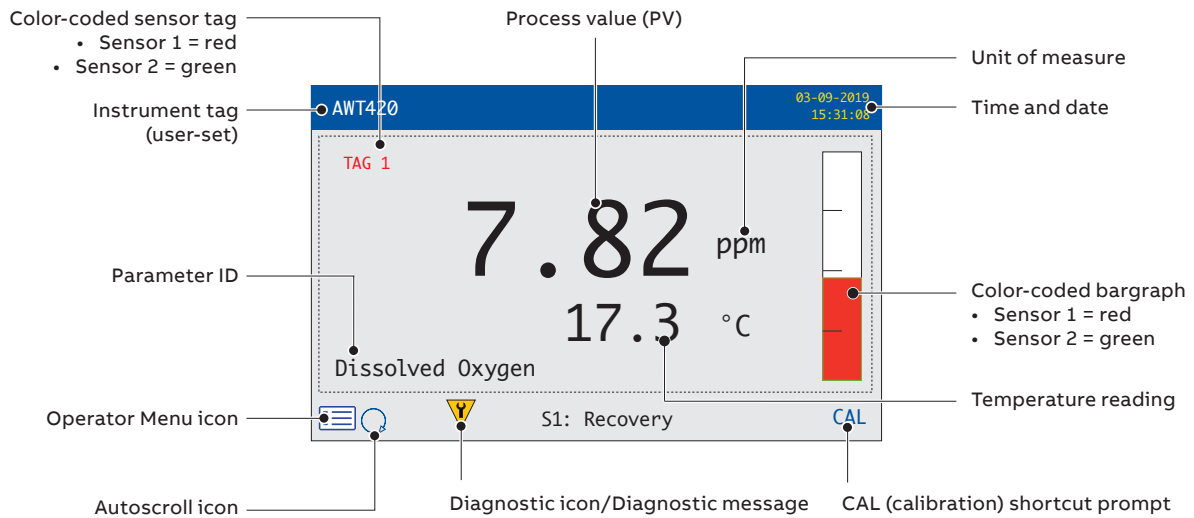

**Figure 21 Operator pages – overview**

## View mode

Pages displayed in View mode comprise:

- **Diagnostics View** – displays a list of active diagnostic messages identified by priority and message – see Figure 17
- **Signals View** – displays a list of active signals and their values (1 page per sensor) – see Figure 23
- **Chart View** – represents the sensor readings as a series of color-coded traces – see Figure 24
- **Alarms View** – displays a list of alarms, source and status – see Figure 25
- **Outputs View** – displays a list of the analog outputs, output value and percentage of output value – see Figure 26

### Diagnostics View

NAMUR icon and message priority – see page 64

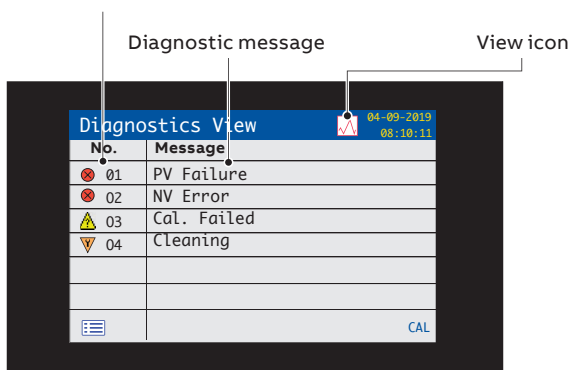

Figure 22 Diagnostics View

### Signals View

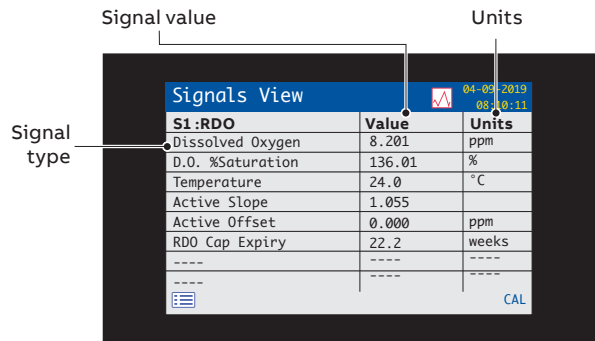

Figure 23 Signals View

### Chart View

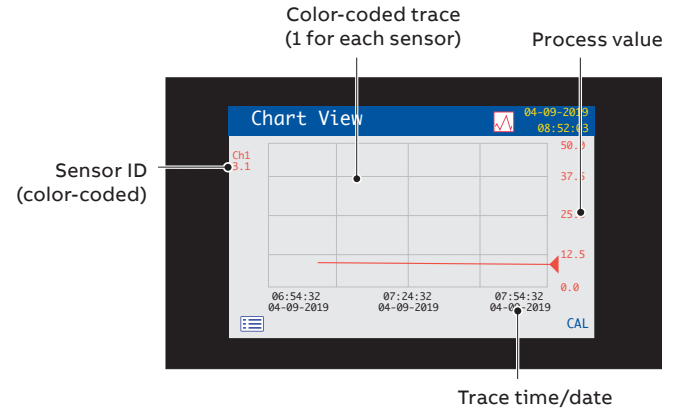

Figure 24 Chart View

### Alarms View

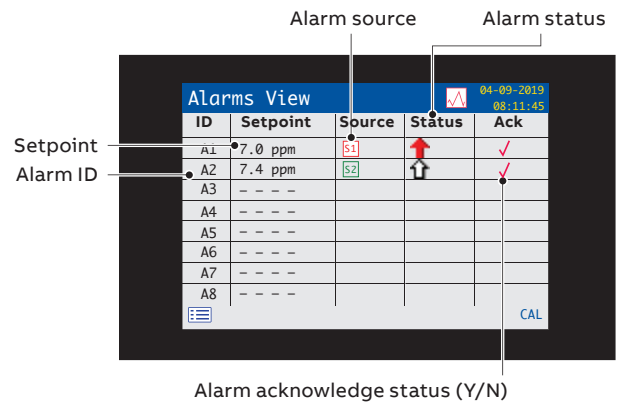

Figure 25 Alarms View

### Outputs View

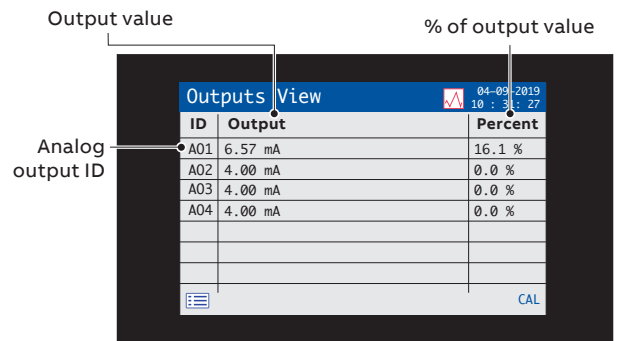

Figure 26 Outputs View

## ...7 Operation

### Log mode

Log mode pages display logged information in the sequence it occurred.

Log mode pages comprise:

- **Calibration Logs:** a history of calibration routines. One log is provided for each sensor and is displayed only if the sensor is fitted. Each log can store 15 entries that are displayed in date order.
- **Alarm Log:** a history of alarm events.
- **Audit Log:** a history of analyzer activity.
- **Diagnostics Log:** a history of diagnostic events.

### Log entries

Example Calibration Log entries with descriptions are shown in Table 2. Example Audit Log entries together with a description are shown in Table 3. The Diagnostics Log shows the history of diagnostic messages that have been displayed in the Diagnostic View – see page 26.

Log entry	Description
Cal Failed	Calibration procedure failed due to low slope or sample temperature error.
Cal Aborted	Calibration aborted manually by the user.
Cal Missed	<b>Note.</b> Sensor-type specific.

**Table 2 Calibration Log entries**

Log entry	Description
Power Failure	Power to the transmitter is lost.
Power Recovery	Transmitter restarted after a power loss.
In Config.	User in Advanced/Configuration mode.
Time/Date Changed	User has changed date/time.
Daylight Saving	Time changed due to daylight saving.

**Table 3 Audit Log entries**

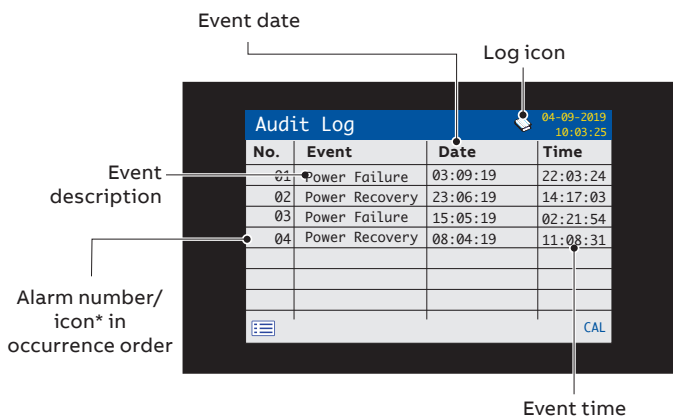

\*Icons not displayed on Alarm Log or Calibration Log

**Figure 27 Log page example (Audit Log shown)**

## 8 Data logging

### Removable SD card

#### An SD card is kept in the transmitter

Data is archived to the removable media automatically at set intervals. Archiving continues until the removable media is full, archiving then stops. To ensure all required data is archived successfully, swap the SD card periodically for an empty one.

#### NOTICE

- Logging of data is possible only when an SD card is fitted and online – in this state, Data and Events are lost.
- ABB's DataManager Pro software can be used to store and view data archived from the transmitter.
- A 2 GB SD card has sufficient external storage capacity for >5 years data.

### Removable media

#### NOTICE

- To avoid potential damage or corruption to data recorded on removable media, take care when handling and storing.
- Do not expose to static electricity, electrical noise or magnetic fields.
- When handling an SD card, take care not to touch any exposed metal contacts.
- Back-up critical data stored on removable media regularly.

### SD card insertion and removal

Referring to Figure 28:

- 1 Using a suitable screwdriver, release door retaining screw (A).
- 2 Open the transmitter door and remove media cover (B).
- 3 Insert removable media (C) by pushing up into slot, then releasing to spring-lock in place. If required, press button (D) to place the media online. LED (E) is lit when the removable media is online.
- 4 To remove the media, if LED (E) is lit, press button (D) to take the media offline and ensure LED (E) is not lit.
- 5 Push removable media (C) up to release spring-lock, then pull down and out of the socket.

(The media can then be inserted into an appropriate card reader on a PC and the data downloaded.)

- 6 Refit media cover (B).
- 7 Close the transmitter door and secure with door retaining screw (A).

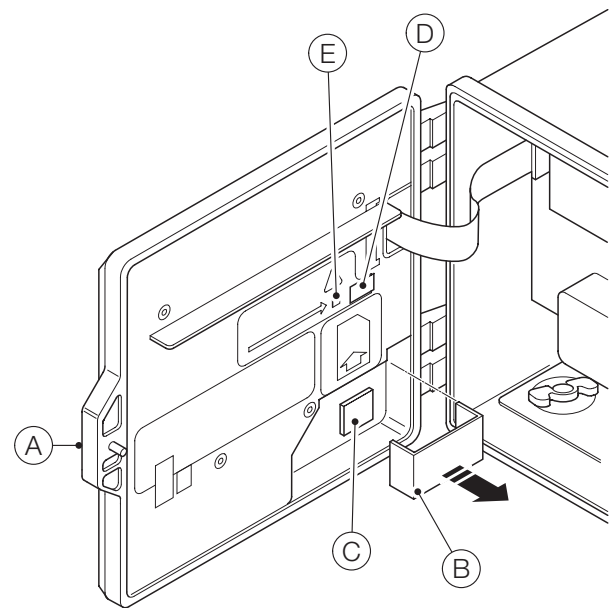

Figure 28 SD card insertion and removal

## 9 Password security and Access Level

### Setting passwords

Passwords are entered at the Enter Password screen accessed via the Access Level see Figure 29.

Passwords can be set to enable secure access at 2 levels: Calibrate and Advanced. The Service level is password protected at the factory and reserved for factory use only. Passwords can contain up to 6 characters and are set, changed or restored to their default settings at the Device Setup/ Security Setup parameter – see page 29.

#### NOTICE

When the transmitter is powered-up for the first time, the Calibrate and Advanced levels can be accessed without password protection. Protected access to these levels can be allocated as required.

### Access Level

The Access Level is entered via the Operator menu/Enter Configuration menu option – see page 20.

Access levels – scroll to level using the  $\Delta/\nabla$  keys and press the  $\blacktriangleright$  key (Select) to enter

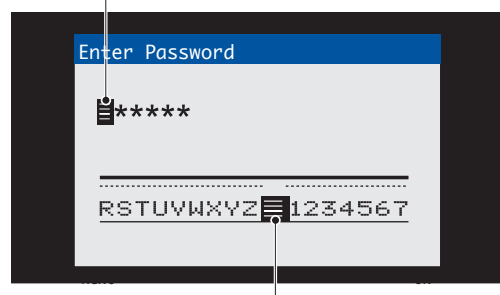

Figure 29 Access level screen

Level	Access
Logout	Displayed only after Calibrate or Advanced levels are accessed. Logs the user out of the current level. If passwords are set, a password must be entered to access these levels again after selecting Logout.
Read Only	View all parameters in read-only mode.
Calibrate	Enables access and adjustment of Calibrate parameters. Calibration is sensor-specific – refer to the sensor Operating instruction for calibration details.
Advanced	Enables configuration access to all parameters.
Service	Reserved for authorized service technicians only.

Table 4 Access level menu details

Cursor/Password character indicator (maximum 6 characters)



Cursor – scroll characters using the  $\Delta/\nabla$  keys; press  $\blacktriangleright$  (Next) to accept character; press  $\blacktriangleright$  (OK) to accept password while last character is highlighted

Figure 30 Enter password screen

# 10 Sensor setup

## 2-electrode conductivity

Menu	Comment	Default
<b>Tag</b>	Enter an alphanumeric sensor tag (16 characters maximum) to identify the sensor on the Operator Pages.	TAG1
<b>Measurement Type</b>	Select measurement type: • Conductivity/Concentration/Resistivity <b>Note.</b> If a change is made the I/O sources are reset.	Conductivity
<b>Note.</b> The following menus are displayed only if measurement type = <b>Conductivity</b>		
<b>Conductivity Unit</b>	Select the conductivity units: • mS/cm/μS/cm	μS/cm
<b>Cell Constant</b>	Enter the cell constant of the measuring cell used – see the relevant conductivity cell manual.	1.00
<b>Range High</b>	Set the span value used in <b>Chart</b> and <b>Bargraph</b> views.	Cell constant dependent – see table below
<b>Range Low</b>	Set the zero value used in <b>Chart</b> and <b>Bargraph</b> views.	0
<b>Note.</b> The following menus are displayed only if measurement type = <b>Concentration</b>		
<b>Cell Constant</b>	Enter the cell constant of the measuring cell used – see the relevant conductivity cell manual.	N/A
<b>Concentration Unit</b>	Select the concentration units: • None(Blank)/ppm/mg/l/ppb/μg/l%/Custom	N/A
<b>Custom Units</b>	<b>Note.</b> Displayed only if concentration units = <b>Custom</b> Enter an alphanumeric string (6 characters maximum) for the custom (user defined) concentration units.	N/A
<b>Conc. Curve Table</b>	Set the user defined concentration curve using the 6-point linearizer table (concentration against conductivity).	N/A
<b>Range High</b>	View the span value used in <b>Chart</b> and <b>Bargraph</b> views.	N/A
<b>Range Low</b>	View the zero value used in <b>Chart</b> and <b>Bargraph</b> views.	N/A
<b>Filter Type</b>	Select the signal filtering type: • None/Low/Medium/High	None
<b>Temp. Comp. Type</b>	Set the type of temperature compensation: • Manual/Automatic/None	Automatic
<b>Manual Temperature</b>	<b>Note.</b> Displayed only if temperature compensation type = <b>Manual</b> Enter the temperature of the sample within the range –10.0 to 120.0 °C.	25.0 °C
<b>TC Curve</b>	<b>Note.</b> Not displayed only if temperature compensation type = <b>None</b> Set the temperature compensation characteristic required: • TC Coeff./Standard KCl/UPW (Low TC)/UPW (High TC)/Pure H2O (Neutral)/Pure H2O (Acid)/Pure H2O (Base)/NaOH/HCl/NaCl/NH3/User Defined	TC Coeff
<b>User Def. TC Curve</b>	<b>Note.</b> Displayed only if temperature compensation curve = <b>User Defined</b> Set the user defined temperature compensation curve using the six point linearizer table (% against °C).	N/A
<b>TC Coefficient</b>	<b>Note.</b> Displayed only if temperature compensation curve = <b>User Defined</b> Enter the temperature coefficient (α x 100) of the solution (0.01 to 5.00 %/°C). If unknown, the temperature coefficient (α) of the solution must be calculated – see page 72.	2.00 %/°C
<b>Sensor Diagnostics</b>		
<b>Polarisation</b>	Detect excessive polarisation condition: • Enabled/Disabled	Disabled
<b>Out Of Solution</b>	Detect <b>Out Of Solution</b> condition: • Enabled/Disabled	Disabled
<b>Reset To Defaults</b>	Select to reset all <b>Sensor Setup</b> parameters to their default values.	

Conductivity cell constant	Conductivity measuring range
0.01	0 to 200 μS/cm
0.05	0 to 1000 μS/cm 0 to 1 mS/cm
0.10	0 to 2,000 μS/cm 0 to 2 mS/cm
1.00	0 to 20,000 μS/cm 0 to 20 mS/cm

## ...10 Sensor setup

### 2-electrode conductivity – dual input calculated values setup

Menu	Comment	Default
<b>Calculation Type</b>	<p>Calculations are performed using the inputs from both sensors. Select the required calculation from the following options: No Calculation/Inferred pH (NaOH)/Inferred pH (NaOH+NaCl)/Inferred pH (NH3)/ Inferred pH (NH3+NaCl)/Difference/Ratio/% Passage/% Rejection</p> <p><b>Inferred pH (NaOH)</b> Calculates a pH value in the range 7.00 to 11.00 pH based on the type of chemical dosing and the conductivity readings. <b>Note:</b> The temperature compensation characteristic TC Curve for signal B should be set to NaOH.</p> <p><b>Inferred pH (NaOH+NaCl)</b> Calculates a pH value in the range 7.00 to 11.00 pH based on the type of chemical dosing and the conductivity readings. <b>Note:</b> The temperature compensation characteristic TC Curve for signal A should be set to NaCl. <b>Note:</b> The temperature compensation characteristic TC Curve for signal B should be set to NaOH.</p> <p><b>Inferred pH (NH3)</b> Calculates a pH value in the range 7.00 to 10.00 pH based on the type of chemical dosing and the conductivity readings. <b>Note:</b> The temperature compensation characteristic TC Curve for signal B should be set to NH3.</p> <p><b>Inferred pH (NH3+NaCl)</b> Calculates a pH value in the range 7.00 to 10.00 pH based on the type of chemical dosing and the conductivity readings. <b>Note:</b> The temperature compensation characteristic TC Curve for signal A should be set to NaCl. <b>Note:</b> The temperature compensation characteristic TC Curve for signal B should be set to NH3.</p> <p><b>Difference</b> Calculates the difference between the two conductivity inputs: Difference = B — A</p> <p><b>Ratio</b> Calculates the ratio of the two conductivity inputs: <math display="block">\text{Ratio} = \frac{B}{A}</math></p> <p><b>% Passage</b> Calculates the amount of conductivity as a percentage that passes through the cation exchange unit: <math display="block">\% \text{Passage} = \frac{A}{B} \times 100</math></p> <p><b>% Rejection</b> Calculates the amount of conductivity as a percentage that is absorbed in the cation exchange unit: <math display="block">\% \text{Rejection} = \left(1 - \frac{A}{B}\right) \times 100</math></p>	No Calculation
<b>Note.</b> The following menus are displayed only if Calculation Type = Inferred pH.		
<b>Before Cation Limit</b>	<p>Set the required before-cation conductivity limit, between:</p> <ul style="list-style-type: none"> <li>• 0.000 and 100.0 µS/cm      Inferred pH (NaOH)</li> <li>• 0.000 and 100.0 µS/cm      Inferred pH (NaOH+NaCl)</li> <li>• 0.000 and 25.00 µS/cm      Inferred pH (NH3)</li> <li>• 0.000 and 25.00 µS/cm      Inferred pH (NH3+NaCl)</li> </ul>	N/A
<b>After Cation Limit</b>	<p>Set the required before-cation conductivity limit, between:</p> <ul style="list-style-type: none"> <li>• 1.000 and 100.0 µS/cm      Inferred pH (NaOH)</li> <li>• 1.000 and 250.0 µS/cm      Inferred pH (NaOH+NaCl)</li> <li>• 0.060 and 10.00 µS/cm      Inferred pH (NH3)</li> <li>• 0.060 and 25.00 µS/cm      Inferred pH (NH3+NaCl)</li> </ul>	N/A
<b>pH Range</b>	<p>View the measuring range for the selected Inferred pH calculation</p> <ul style="list-style-type: none"> <li>• 7.00 to 11.00 pH      Inferred pH (NaOH)</li> <li>• 7.00 to 11.00 pH      Inferred pH (NaOH+NaCl)</li> <li>• 7.00 to 10.00 pH      Inferred pH (NH3)</li> <li>• 7.00 to 10.00 pH      Inferred pH (NH3+NaCl)</li> </ul>	N/A
<b>Signal Arrangement</b>	<p>Set the signal arrangement:</p> <ul style="list-style-type: none"> <li>• A = S1, B = S2/A = S2, B = S1</li> </ul> <p><b>Note:</b> For inferred pH:</p> <ul style="list-style-type: none"> <li>• A = Conductivity measurement <b>A</b>fter cation column.</li> <li>• B = Conductivity measurement <b>B</b>efore cation column.</li> </ul>	N/A

## 4-electrode conductivity

Menu	Comment	Default
<b>Tag</b>	Enter an alphanumeric sensor tag (16 characters maximum) to identify the sensor on the Operator Pages.	TAG1
<b>Measurement Type</b>	Select measurement type: <ul style="list-style-type: none"> <li>• Conductivity/Concentration</li> </ul> <b>Note.</b> If a change is made the I/O sources are reset.	Conductivity
<b>Note.</b> The following menus are displayed only if <b>Measurement Type = Conductivity</b>		
<b>Conductivity Unit</b>	Select the conductivity units: <ul style="list-style-type: none"> <li>• mS/cm/μS/cm</li> </ul>	mS/cm
<b>Sensor Group</b>	Enter the sensor group for the measuring cell used – <ul style="list-style-type: none"> <li>• Group A/Group B</li> </ul> see the relevant conductivity cell manual.	Group A
<b>Range High</b>	Set the span value used in Chart and Bargraph views.	Sensor Group dependent – see table below
<b>Range Low</b>	Set the zero value used in Chart and Bargraph views.	0
<b>Note.</b> The following menus are displayed only if <b>Measurement Type = Concentration</b>		
<b>Sensor Group</b>	Enter the sensor group for the measuring cell used – <ul style="list-style-type: none"> <li>• Group A/Group Bw</li> </ul> see the relevant conductivity cell manual.	N/A
<b>Conc. Solution</b>	<b>Note.</b> Displayed only if <b>Sensor Group = Group A</b> Select the Concentration Solution <ul style="list-style-type: none"> <li>• NaOH/HCl/H2SO4/H3PO4/NaCl/KOH/Custom</li> </ul>	N/A
<b>Concentration Unit</b>	<b>Note.</b> Displayed only if <b>Conc. Solution = Custom</b> Select the Concentration Units <ul style="list-style-type: none"> <li>• None(Blank)/ppm/mg/l/ppb/μg/l/%/Custom</li> </ul>	N/A
<b>Custom Units</b>	<b>Note.</b> Displayed only if <b>Concentration Units = Custom</b> Enter an alphanumeric string (6 characters maximum) for the custom (user defined) concentration units.	N/A
<b>Conc. Curve Table</b>	Set the user defined concentration curve using the 6-point linearizer table (concentration against conductivity).	N/A
<b>Range High</b>	View the span value used in Chart and Bargraph views.	N/A
<b>Range Low</b>	View the zero value used in Chart and Bargraph views.	N/A
<b>Filter Type</b>	Select the signal filtering type: <ul style="list-style-type: none"> <li>• None/Low/Medium/High</li> </ul>	None
<b>Temp. Comp. Type</b>	Set the type of temperature compensation: <ul style="list-style-type: none"> <li>• Manual/Automatic/None</li> </ul>	Automatic
<b>Manual Temperature</b>	<b>Note.</b> Displayed only if <b>Temp. Comp. Type = Manual</b> Enter the temperature of the sample within the range –10.0 to 120.0 °C.	25.0 °C
<b>TC Curve</b>	<b>Note.</b> Not displayed only if <b>Temp. Comp. Type = None</b> Set the type of automatic temperature compensation required: <ul style="list-style-type: none"> <li>• TC Coeff./Standard KCl/NaOH/NaCl/HCl/H2SO4/H3PO4/KOH/User Defined</li> </ul>	TC Coeff
<b>User Def. TC Curve</b>	<b>Note.</b> Displayed only if <b>TC Curve = User Defined</b> . Set the user defined temperature compensation curve using the six point linearizer table (% against °C).	N/A
<b>TC Coefficient</b>	<b>Note.</b> Displayed only if <b>TC Curve = User Defined</b> . Enter the temperature coefficient ( $\alpha \times 100$ ) of the solution (0.01 to 5.00 %/°C). If unknown, the temperature coefficient ( $\alpha$ ) of the solution must be calculated – see page 97.	2.00 %/°C
<b>Sensor Diagnostics</b>		
<b>Dirty Sensor</b>	Detect dirty sensor condition: <ul style="list-style-type: none"> <li>• Enabled/Disabled</li> </ul>	Disabled
<b>Out Of Solution</b>	Detect Out Of Solution condition: Enabled/Disabled	Disabled
<b>Reset To Defaults</b>	Select to reset all Sensor Setup parameters to their default values	

Sensor group	Conductivity measuring range
A	0 to 2000 mS/cm
B	0 to 2000 μS/cm

## ...10 Sensor setup

### pH/Redox/ORP

Menu	Comment	Default
<b>Tag</b>	Enter an alphanumeric sensor tag (16 characters maximum) to identify the sensor on the Operator Pages.	TAG1
<b>Measurement Type</b>	Select measurement type: <ul style="list-style-type: none"> <li>pH/Redox/ORP</li> </ul> <b>Note.</b> If a change is made the I/O sources are reset.	pH
<b>Range High</b>	Set the span value used in Chart and Bargraph views.	14.00
<b>Range Low</b>	Set the zero value used in Chart and Bargraph views.	0.00
<b>Filter Type</b>	Select the signal filtering type: <ul style="list-style-type: none"> <li>None/Low/Medium/High</li> </ul>	None
<b>Note.</b> The following menus are displayed only if Measurement Type = pH.		
<b>Temp. Compensation</b>	Set the type of temperature compensation: <ul style="list-style-type: none"> <li>Manual/Automatic/Auto solution</li> </ul>	Automatic
<b>Solution Coeff.</b>	<b>Note.</b> Displayed only if Temp. Compensation type = Auto solution. Set the solution coefficient (pH or mV change per 10 deg C) of the solution being monitored. See Appendix A, page 97.	N/A
<b>Manual Temperature</b>	<b>Note.</b> Displayed only if Temp. Compensation type = Manual. Enter the temperature of the sample within the range -10.0 to 120.0 °C.	N/A
<b>Note.</b> The following menus are displayed only if Measurement Type = Redox/ORP.		
<b>Temperature Sensor</b>	Set the type of temperature measurement: <ul style="list-style-type: none"> <li>Manual/Automatic</li> </ul> <b>Note.</b> If Temperature Sensor type = Manual, the temperature value is not displayed in the associated Operator page or Signals View.	N/A
<b>Low Slope Limit</b>	A pH probe degrades over time. As this happens the slope calculated by a calibration procedure gradually decreases. Set the slope value below which a calibration fails. The low slope warning diagnostic is activated if the calibration calculates a slope less than 20 % above this value.	40%
<b>Sensor Diagnostics</b>		
<b>Broken Glass</b>	<b>Note:</b> Displayed only if Measurement Type = pH. Detect broken glass condition: <ul style="list-style-type: none"> <li>Enabled/Disabled</li> </ul>	Disabled
<b>Out Of Solution</b>	Detect Out Of Solution condition: <ul style="list-style-type: none"> <li>Enabled/Disabled</li> </ul>	Disabled
<b>Ref. Poisoning</b>	<b>Note:</b> Displayed only if a digital (EZLink) sensor is connected. Detect a contaminated reference electrode: <ul style="list-style-type: none"> <li>Enabled/Disabled</li> </ul>	Disabled
<b>Ref. Failure</b>	<b>Note:</b> Displayed only if a digital (EZLink) sensor is connected. Detect a failed reference electrode: <ul style="list-style-type: none"> <li>Enabled/Disabled</li> </ul>	Disabled
<b>Ref. Blocked</b>	Detect a blocked reference electrode: <ul style="list-style-type: none"> <li>Enabled/Disabled</li> </ul>	Disabled
<b>Ref. Alarm Limit</b>	<b>Note:</b> Displayed only if Ref. Blocked sensor diagnostic is Enabled. A blocked reference electrode is detected when the impedance of the reference electrode exceeds a given limit. Set the impedance value above which the reference blocked diagnostic is activated.	N/A
<b>Reset To Defaults</b>	Select to reset all Sensor Setup parameters to their default values.	

## RDO

Menu	Comment	Default
<b>Tag</b>	Enter an alphanumeric sensor tag (16 characters maximum) to identify the sensor on the <b>Operator Pages</b> .	TAG1
<b>Measurement Type</b>	Select the required probe type: <ul style="list-style-type: none"> <li>Dissolved Oxygen/% Saturation</li> </ul> <b>Note.</b> If a change is made the I/O sources are reset.	Dissolved Oxygen
<b>Units</b>	Select the measurement units: <ul style="list-style-type: none"> <li>mg/l/ppm</li> </ul>	ppm
<b>PV Resolution</b>	Select the PV Resolution: <ul style="list-style-type: none"> <li>Normal/High</li> </ul>	Normal
<b>Range High</b>	Set the span value in <b>Chart</b> and <b>Bargraph</b> views.	50 ppm (200%)
<b>Range Low</b>	Set the zero value in <b>Chart</b> and <b>Bargraph</b> views.	0
<b>Filter Type</b>	Select the signal filtering type: <ul style="list-style-type: none"> <li>None/Low/Medium/High</li> </ul>	None
<b>Salinity Unit</b>	Select the required salinity units: <ul style="list-style-type: none"> <li>PSU (Practical Salinity Units) or ppt (parts-per-thousand).</li> </ul>	PSU
<b>Salinity Correction</b>	Required when monitoring water containing high quantities of dissolved salts: <ul style="list-style-type: none"> <li>enter the required value between 0 and 42 Practical Salinity Units (PSU).</li> <li>leave at the default value of 0 PSU if salinity correction is not required.</li> </ul>	0 PSU
<b>Pressure Unit</b>	Select the required barometric pressure units: <ul style="list-style-type: none"> <li>mBar/mmHg</li> </ul>	mBar
<b>Barometric Pressure</b>	Barometric pressure compensation. Set the local barometric pressure to 506 to 1114 mbar (380 to 835 mm/Hg). If the barometric pressure is unknown, leave at the default sea-level value of 1013 mbar (760 mm/Hg).	1013 mbar
<b>Reset To Defaults</b>	Select to reset all <b>Sensor Setup</b> parameters to their default values.	N/A

## Turbidity/Suspended solids

Menu	Comment	Default
<b>Tag</b>	Enter an alphanumeric sensor tag (16 characters maximum) to identify the sensor on the <b>Operator Pages</b> .	TAG1
<b>Measurement Type</b>	Select measurement type: <ul style="list-style-type: none"> <li>Turbidity/Suspended solids</li> </ul> <b>Note.</b> If a change is made the I/O sources are reset.	Turbidity
<b>Turbidity Units</b>	Select the turbidity units <ul style="list-style-type: none"> <li>NTU/FNU</li> </ul>	NTU
<b>TSS Units</b>	Select the total suspended solids units <ul style="list-style-type: none"> <li>mg/l/ppm</li> </ul> for readings above 1000 mg/l (ppm) the units change automatically to g/l (ppt).	mg/l
<b>Range High</b>	Set the span value used in <b>Chart</b> and <b>Bargraph</b> views.	4000 NTU
<b>Range Low</b>	Set the zero value used in <b>Chart</b> and <b>Bargraph</b> views.	0
<b>Filter Type</b>	Select the signal filtering type: <ul style="list-style-type: none"> <li>None/Low/Medium/High</li> </ul>	None
<b>Note.</b> The following menus are displayed only if the sensor has a wiper fitted.		
<b>Wiper Clean Freq.</b>	Set the interval between cleans: <ul style="list-style-type: none"> <li>Off/15 mins/30 mins/45 mins/1 to 24 Hours</li> </ul>	Off
<b>Next Clean</b>	<b>Note.</b> Displayed only if a wiper clean frequency has been configured Set the time for the next wiper clean to occur.	N/A
<b>Reset Wiper Lifetime</b>	Use to restart the wiper lifetime counter after wiper replacement.	N/A
<b>Reset To Defaults</b>	Select to reset all <b>Sensor Setup</b> parameters to their default values.	

## 11 Specification

### Operation

#### Display

89 mm (3.5 in) color ¼ VGA TFT, liquid crystal display (LCD) with built-in backlight and brightness/contrast adjustment

#### Language

English, German, French, Italian, Spanish

#### Keypad

- 6 tactile membrane keys:
  - Group select/Left cursor
  - View select/Right cursor
  - Menu key
  - Up
  - Down
  - Enter key

#### No. of inputs

Up to 2 analog or digital sensors

### Mechanical data

#### Protection

IP66/NEMA 4X

#### Dimensions

- Height: 144 mm (5.67 in) minimum (excluding glands)
- Width: 144 mm (5.67 in) door closed – min.
- Depth: 99 mm (3.89 in) door closed – min. (excluding fixing brackets)
- Weight: aluminium enclosure  
1.36 kg (3 lb) approx. (unpacked)
- Weight: polycarbonate enclosure  
1 kg (2.2 lb) approx. (unpacked)

#### Panel dimensions

- Cut-out height: 138 +1 –0 mm (5.43 +0.04 –0 in)
- Cut-out width: 138 +1 –0 mm (5.43 +0.04 –0 in)
- Thickness: 6.35 mm (0.25 in) max.
- Depth behind panel: 100 mm (4 in) min. (after fixing with brackets to panel)
- Distance between cut-outs: 40 mm (1.57 in) min.

#### Materials of construction

- Aluminium enclosure – LM20 aluminium
- Polycarbonate enclosure – LEXAN 505RU  
10 % glass-filled polycarbonate

#### Cable entries

- Five holes to accept M20 or ½ in cable glands or conduit hubs
- Two holes to accept M16 cable glands or conduit hubs or EZLink connectors

### Security

#### Password protection

Access to configuration levels is enabled only after the user has entered a password:

- Calibrate level: user-assigned password
- Advanced level: user-assigned password
- Service level: service level user-assigned password

### Electrical

#### Supply voltage

- 100 to 240 V AC ±10 %, 50/60 Hz
- 24 V DC (18 min. to 36 V DC max.)

#### Power consumption

<15W

#### Terminal connections rating

- Solid/Flexible wire: AWG 24 to 16 (0.2 to 1.5 mm<sup>2</sup>)
- Ferrule with plastic sleeve 0.2 to 0.75 mm<sup>2</sup>
- Ferrule without plastic sleeve 0.2 to 1.5 mm<sup>2</sup>

#### Cable specification

Cable glands:

- M20: 5 to 9 mm (0.2 to 0.35 in)
- M16: 2 to 6 mm (0.08 to 0.24 in)
- ½ in NPT: 6 to 12 mm (0.24 to 0.47 in)
- Ethernet: 4.7 to 6.35 mm (0.187 to 0.25 in)

### Analog outputs

#### Number

- Two supplied as standard
- Four with module board fitted

#### Output ranges

Analog output programmable to any value between 0 and 22 mA to indicate system failure

#### Accuracy

±0.25 % of reading or 10 µA (whichever is the greater)

#### Maximum load resistance

500Ω at 20 mA

#### Configuration

Can be assigned to either measured variable or either sample temperature

#### Isolation

500 V DC from any other circuitry but not from each other

### Relay outputs

- 4 standard single-pole changeover
- Fully-programmable
  - Contacts rating: 5A @ 110/240 V AC (Non-Inductive) 5A @ 30 V DC

### Digital input/output

- 1 standard, user-programmable as input or output
- Minimum input pulse duration: 125 ms
- Input – volt-free
- Output – open-collector, 12 to 24 V, 250 mA max.

## Connectivity/Communications (optional)

### Ethernet

HTTP, HTTPS, FTP, Secure FTP

### PROFIBUS DP

DPV0, DPV1

### MODBUS

RTU RS485

### HART

- Fieldcomm certified version – HART 7
- Configured range
  - 4 to 20 mA, user-programmable across measurement range
- Dynamic range
  - 3.8 to 20.5 mA with 3.6 mA low alarm level, 21 mA high alarm level
- Accuracy
  - $\pm 0.25$  % of reading
- Maximum load resistance
  - 500  $\Omega$  at 20 mA
- Configuration
  - Can be assigned to either measured variable
- Isolation
  - 500 V DC from any other circuitry

## Data logging

### Storage

- Measurement value storage (programmable sample rate)
- Audit log\*, Alarm log\*, Calibration log, Diagnostics log

### Storage media

SD card, up to 32 GB capacity

### Chart view

On local display

### Historical review

Of data

### Data transfer

SD card interface – Windows-compatible FAT file system, data and log files in Excel and DataManager Pro compatible formats

## Environmental data

### Ambient operating temperature:

–10 to 55 °C (14 to 131 °F)

### Ambient operating humidity:

Up to 95 % RH non-condensing

### Storage temperature:

–20 to 70 °C (–4 to 158 °F)

### Altitude:

2000 m (6562 ft) max. above sea level

## 2-electrode conductivity

### Conductivity input

#### Measurement range and resolution

Cell constant	Conductivity range	Display resolution	Accuracy repeatability
0.01	0 to 200 $\mu\text{S/cm}$	0.001 $\mu\text{S/cm}$	$\pm 1.0$ % of measurement range per decade
0.05	0 to 1000 $\mu\text{S/cm}$	0.001 $\mu\text{S/cm}$	
0.1	0 to 2000 $\mu\text{S/cm}$	0.01 $\mu\text{S/cm}$	
1	0 to 20000 $\mu\text{S/cm}$	0.1 $\mu\text{S/cm}$	

#### Dynamic response

<3 s for 90 % step change when damping is Off

#### Damping

Configurable: Off, Low, Medium and High

### Temperature input

#### Temperature element types

- Automatic temperature sensor recognition for Pt100, Pt1000 and 3k Balco RTDs in either 2-lead or 3-lead configurations
- Temperature element can be used for automatic temperature compensation of the conductivity solution

#### Measurement range and resolution

Sensor group	Temperature range	Display resolution	Accuracy repeatability
Pt100	–20 to 200 °C	0.1 °C (0.1 °F)	0.1 °C (0.18 °F)
Pt1000	(–4 to 392 °F)		N/A
3K Balco			
None	User-programmable –20 to 300 °C (–4 to 572 °F)		

#### Temperature compensation modes

Linear, UPW, NaCl, HCl and  $\text{NH}_3$

#### Reference temperature

25 °C (77 °F)

### Configured output range

Cell constant	Min. span	Max. span
0.01	1 $\mu\text{S/cm}$	200 $\mu\text{S/cm}$
0.05	5 $\mu\text{S/cm}$	1000 $\mu\text{S/cm}$
0.1	10 $\mu\text{S/cm}$	2000 $\mu\text{S/cm}$
1	100 $\mu\text{S/cm}$	20000 $\mu\text{S/cm}$

\* Audit log and Alarm log data are stored in the same log file.

## ...11 Specification

### 4-electrode conductivity

#### Conductivity input

##### Measurement range and resolution

Sensor group	Conductivity range	Display resolution	Accuracy repeatability
A	0 to 2000 mS/cm	0.1 $\mu$ S/cm	$\pm$ 0.5 % of measurement range per decade
B	0 to 2000 $\mu$ S/cm	0.01 $\mu$ S/cm	

##### Dynamic response

<3 s for 90 % step change when damping is Off

##### Damping

Configurable: Off, Low, Medium and High

#### Temperature input

##### Temperature element types

- Automatic temperature sensor recognition for Pt100, Pt1000 and 3k Balco RTDs in either 2-lead or 3-lead configurations
- Temperature element can be used for automatic temperature compensation of the conductivity solution

##### Measurement range and resolution

Sensor group	Temperature range	Display resolution	Accuracy repeatability
Pt100	-20 to 200 °C (-4 to 392 °F)		0.1 °C (0.18 °F)
Pt1000			
3K Balco		0.1 °C (0.1 °F)	
None	User-programmable -20 to 300 °C (-4 to 572 °F)		N/A

##### Temperature compensation modes

- 0 to 15 % NaOH
- 0 to 18 % HCl
- 0 to 20 % H<sub>2</sub>SO<sub>4</sub>
- 0 to 40 % H<sub>3</sub>PO<sub>4</sub>
- 0 to 20 % NaCl
- 0 to 50 % KOH
- User-defined table

##### Reference temperature

25 °C (77 °F)

#### Configured output range

Sensor group	Min. span	Max. span
A	100 $\mu$ S/cm	2000 mS/cm
B	10 $\mu$ S/cm	2000 $\mu$ S/cm

### pH/ORP (Redox)

#### pH/ORP (Redox) input

##### Sensor types

pH: Glass, Antimony (Sb)

ORP (Redox): Platinum (Pt), Gold (Au)

##### Input impedance

>1 $\times$ 10<sup>13</sup>  $\Omega$

##### Measurement range and resolution

Type	Range	Display resolution	Accuracy repeatability
pH	0 to 14 pH	0.01 pH	$\pm$ 0.01 pH
ORP	$\pm$ 2000 mV	1 mV	$\pm$ 1800 MV: $\pm$ 1 mV $\pm$ 2000 MV: $\pm$ 3 mV

##### Dynamic response

<3 s for 90 % step change when damping is Off

##### Damping

Configurable: Off, Low, Medium and High

#### Temperature input

##### Temperature element types

- Automatic temperature sensor recognition for Pt100, Pt1000 and 3k Balco RTDs in either 2-lead or 3-lead configurations
- Temperature element can be used for automatic temperature compensation of the conductivity solution

##### Measurement range and resolution

Sensor group	Temperature range	Display resolution	Accuracy repeatability
Pt100	-20 to 200 °C (-4 to 392 °F)		0.1 °C (0.18 °F)
Pt1000			
3K Balco		0.1 °C (0.1 °F)	
None	User-programmable -20 to 300 °C (-4 to 572 °F)		N/A

##### Temperature compensation modes

- pH: Manual, Automatic Nernstian, Nernstian with solution coefficient
- ORP: Manual, solution compensation coefficient

##### Reference temperature

25 °C (77 °F)

#### Configured output range

Type	Min. span	Max. span
pH	1 pH	14 pH
ORP	100 mV	4000 mV

## EZLink

### Power consumption (maximum)

150 mA @ 24 V DC (3.75 W max)

### Fixed length cable

1 or 10 m (3.28 or 32.8 ft)

### Digital sensor connector IP rating

IP67 (when connected)

### Extension cable (options)

1, 5, 10, 15, 25, 50 m (3.2, 16.4, 32, 49.2, 82, 164 ft)

### Maximum length (including optional extension cable)

Up to 210 m (826 ft)

## EMC

### Emissions & immunity

Meets requirements of IEC61326 for an industrial environment

## Approvals, certification and safety

### Safety approval

cULus

### CE mark

Covers EMC & LV Directives  
(including latest version IEC 61010)

### General safety

- IEC 61010-1
- Pollution degree 2
- Insulation class 1

### Bluetooth

The Bluetooth Low Energy Module within the AWT420 transmitter has received the regulatory approval for the following countries:

- Europe/CE



- Japan/MIC: 005-101150

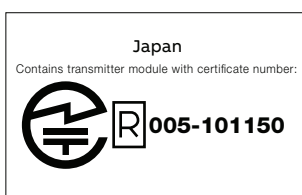

- Korea/KCC: MSIP-CRM-mcp-BM71BLES1FC2



- China/SRRC: CMIIT ID: 2016DJ5890



- United States/FCC ID: A8TBM71S2

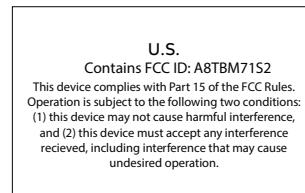

This equipment has been tested and found to comply with the limits for a Class B digital device, pursuant to part 15 of the FCC Rules. These limits are designed to provide reasonable protection against harmful interference in a residential installation. This equipment generates, uses and can radiate radio frequency energy, and if not installed and used in accordance with the instructions, may cause harmful interference to radio communications. However, there is no guarantee that interference will not occur in a particular installation. If this equipment does cause harmful interference to radio or television reception, which can be determined by turning the equipment off and on, the user is encouraged to try to correct the interference by one or more of the following measures:

- Reorient or relocate the receiving antenna.
- Increase the separation between the equipment and receiver.
- Connect the equipment into an outlet on a circuit different from that to which the receiver is connected.
- Consult the dealer or an experienced radio/TV technician for help.

## ...11 Specification

### ...Approvals, certification and safety

#### ...Bluetooth

##### Canada/ISED

- IC: 12246A-BM71S2
- HVIN: BM71BLES1FC2



This device complies with Industry Canada's license-exempt RSS standard(s).

Operation is subject to the following two conditions:

- This device may not cause interference, and
- This device must accept any interference, including interference that may cause undesired operation of the device.

Le présent appareil est conforme aux CNR d'Industrie Canada applicables aux appareils radio exempts de licence.

L'exploitation est autorisée aux deux conditions suivantes:

- l'appareil ne doit pas produire de brouillage, et
- l'utilisateur de l'appareil doit accepter tout brouillage radioélectrique subi, même si le brouillage est susceptible d'en compromettre le fonctionnement

- Taiwan/NCC No: CCAN16LP0011T7



#### 注意！

依據 低功率電波輻射性電機管理辦法  
第十二條 經型式認證合格之低功率射頻電機，  
非經許可，  
公司、商號或使用者均不得擅自變更頻率、加大  
功率或變更原設計  
之特性及功能。  
第十四條 低功率射頻電機之使用不得影響飛航安  
全及干擾合法通信；  
經發現有干擾現象時，應立即停用，並改善至無  
干擾時方得繼續使用。  
前項合法通信，指依電信規定作業之無線電信。  
低功率射頻電機須忍受合法通信或工業、科學及  
醫療用電波輻射性  
電機設備之干擾。

## 12 Spares

### Sensor module assemblies

#### AWT420 pH/ORP PCB upgrade/spares kit

Part number

3KXA877420L0014

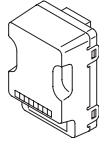

#### AWT420 2-electrode conductivity PCB upgrade/spares kit

Part number

3KXA877420L0013

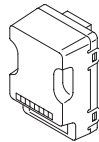

#### AWT420 4-electrode conductivity PCB upgrade/spares kit

Part number

3KXA877420L0011

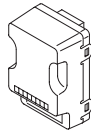

### EZLink module assemblies

#### AWT420 EZLink PCB upgrade/spares kit

Part number

3KXA877420L0015

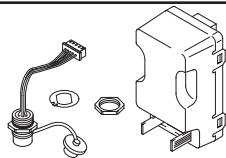

### Communications module assemblies

#### AWT420 HART PCB upgrade/spares kit

Part number

3KXA877420L0051

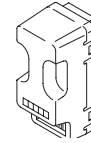

#### AWT420 Profibus PCB upgrade/spares kit

Part number

3KXA877420L0052



#### AWT420 Modbus PCB upgrade/spares kit

Part number

3KXA877420L0054

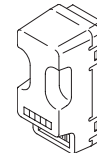

#### AWT420 Ethernet PCB upgrade/spares kit

Part number

3KXA877420L0065

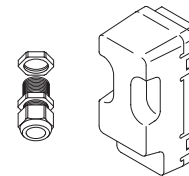

#### AWT420 analog output PCB upgrade/spares kit

Part number

3KXA877420L0056

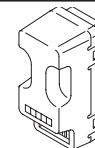

## ...12 Spares

### Mounting kits

#### Panel-mount kit

Part number

3KXA877210L0101 Panel-mount kit, including fixings, flanges, clamps and seal

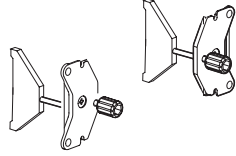

#### Pipe-mount kit

Part number

3KXA877210L0102 Pipe-mount kit, including pipe-mount adapter plate, brackets and fixings (excludes pipe)

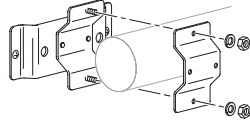

#### Wall-mount kit

Part number

3KXA877210L0105 Wall-mount kit

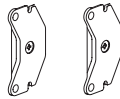

### Weathershield kits

#### Weathershield kit

Part number

3KXA877210L0103

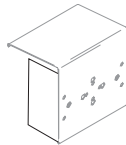

#### Weathershield and pipe-mount kit

Part number

3KXA877210L0104

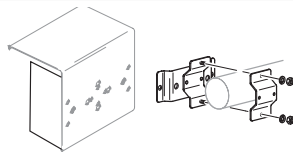

### Gland packs/EZLink connectors

#### Gland packs

Part number

3KXA877420L0111 M20 (qty. 5), M16 (qty. 2)

3KXA877420L0112 ½ in NPT (qty. 5), M16 (qty. 2)

3KXA877420L0113 M20 (qty. 4), M16 (qty. 2) Ethernet (qty. 1)

3KXA877420L0114 ½ in NPT (qty. 4), M16 (qty. 2) Ethernet (qty. 1)

3KXA877420L0115 Ethernet gland (qty. 1)

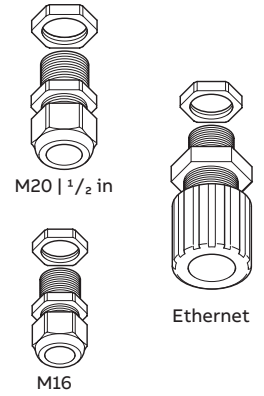

#### EZLink connector assembly

Part number

3KXA877420L0066

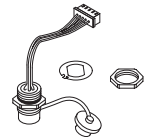

#### EZLink extension cable assembly

Part number Description

AWT4009010 1 m (3.3 ft)  
 AWT4009050 5 m (16.4 ft)  
 AWT4009100 10 m (32.8 ft)  
 AWT4009150 15 m (49.2 ft)  
 AWT4009250 25 m (82.0 ft)  
 AWT4009500 50 m (164.0 ft)  
 AWT4009000 100 m (328.0 ft)

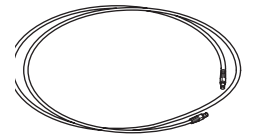

## Acknowledgments

- Microsoft and Excel are registered trademarks of Microsoft Corporation in the United States and/or other countries.
- Android is a trademark of Google LLC.
- Bluetooth is a registered trademark of Bluetooth SIG, Inc.
- HART is a registered trademark of the FieldComm Group
- iOS is a trademark of Apple Inc., registered in the U.S. and other countries.
- LEXAN is a registered trademark of SABIC GLOBAL TECHNOLOGIES B.V.
- Modbus is a registered trademark of Schneider Electric USA Inc.
- PROFIBUS is a registered trademark of PROFIBUS organization.

---

**ABB Limited****Measurement & Analytics**

Oldends Lane, Stonehouse  
Gloucestershire, GL10 3TA  
UK

Tel: +44 (0)1453 826 661

Fax: +44 (0)1453 829 671

Email: [instrumentation@gb.abb.com](mailto:instrumentation@gb.abb.com)

**ABB Inc.****Measurement & Analytics**

125 E. County Line Road  
Warminster, PA 18974  
USA

Tel: +1 215 674 6000

Fax: +1 215 674 7183

[abb.com/measurement](http://abb.com/measurement)



---

We reserve the right to make technical changes or modify the contents of this document without prior notice. With regard to purchase orders, the agreed particulars shall prevail. ABB does not accept any responsibility whatsoever for potential errors or possible lack of information in this document.

We reserve all rights in this document and in the subject matter and illustrations contained therein. Any reproduction, disclosure to third parties or utilization of its contents – in whole or in parts – is forbidden without prior written consent of ABB.